

RUBELLI

CASA





ELEGANCE & INNOVATION BY RUBELLI CASA

Rubelli Casa is the furniture collection designed, produced and distributed by Rubelli.

Launched in 2015, new products have been added to the collection over the years, above all for living areas and dining rooms. Good looks, timeless elegance, comfort, tailored details and sophisticated choices of finishes and textures are the distinguishing features of this collection which, right from the start, has claimed its own special space through the style and design it has to offer.

An all-Italian collection both in terms of creation (to date all the designers are Italian) and production, all strictly Italian made. Rubelli Casa creations are the result of several hands and different personalities, leading to a very varied range with differing moods.

A rationalist mood, that of Luca Scacchetti, inspired by last century's Milanese design maestros, yet softened by details linked to Venetian decorativism. Examples of this are the Forcola cabinet, the Schola Granda Flower table, the Rio Novo desk, the Barbacàn armchair, the Canevin and Clintòn small armchairs.

The strongly contemporary mood of the Cinecittà collection, designed by well-known architect Marco Piva and played out on the use and overlapping of different materials and textures, features sleek lines and geometric shapes to add lightness to the products. Such as for example the Rodolfo tables, the Fellini and Rossellini coffee tables, the Lollo and Marcello sofas and the Silvana and Stefania small chairs.

The vintage mood of Studio Rubelli, its ultimate manifestation found in the Palazzo and Triennale sofas, in the Dadamaino bench and Ascari and Nuvolari chairs. Pieces which, with their vintage spirit, bring the Fifties to mind in a balanced mix of decoration and design.

The innovative mood of the creations of the young designers Nava+Arosio who, after having designed for Rubelli the highly original textile armchair Pila-47, have introduced the Piano capsule collection played out on sculptural yet at the same time "lightweight" elements, able to create very special scenic effects.

The latest collection, created by Matteo Nunziati, has a strongly contemporary mood, yet at the same balanced, coherent and linear.

The classic style is subtly permeated with the past, referencing an idea of order, balance, proportion and harmony among the parts, a passion for detail and manufacturing skills. The Tela

armchair and the Asola modular sofa, like the Frame bookcase, are excellent examples of this.

All Rubelli Casa products are available in a wide range of finishes and in luxury materials, such as Calacatta Vagli marble, walnut, ebony and Eucalyptus pomele, which are often innovative too. They include Damantio®, a material created and patented by Rubelli in 2017.

A perfect union of textile know-how and technological innovation, Damantio® is used as a top in the Greta and Rossellini coffee tables by the architect Piva, as finish in the frames of the Gillo mirrors, and also as "single" material in the Peggy small table by Studio Rubelli, the most eccentric and unconventional piece in the 2019 collection.

The Rubelli Group also offers the opportunity of furnishing your home with actual one-off items. Customers can in fact select from the vast range of Rubelli fabrics the textile coverings for their upholstered items.

Rubelli Casa, the missing link in a new path through the world of furniture and decoration.

Rubelli came into being in 1889 and, right from the start, was extraordinarily successful in translating into an industrial product the vast wealth of the Venetian textile tradition with damask, brocade, velvet and precious silk. It was regenerated through involvement by designers such as Gio Ponti, Roberta di Camerino and more recently Giorgio Armani and Peter Marino and is today considered a benchmark company in the production of home textiles. Ongoing evolution, with the idea of challenging themselves in order to tackle changing times, is typical of art and Italian design.

With the new Rubelli Casa collection Matteo Nunziati has captured the true soul of the company. Delving into tradition and its outstanding features, he has uncovered a complex history with age-old roots.

"I was most struck by the fact that Rubelli has succeeded over the years in constantly rewriting its tradition, remaining true to its identity and at the same time looking ahead."

Inspiration comes from the furnishing of Milanese upper-class residences from the Thirties such as Villa Necchi Campiglio designed by Piero Portaluppi or the works of Gio Ponti and Guglielmo Ulrich, also from those years. Makers therefore who were part of the cultural and artistic movement known as "Novecento", set up in Milan at the end of 1922, with as its supreme reference classical antiquity, the purity of shapes and harmony in the composition, and contaminated by the great Middle-European rationalist and modernist revolution of the Bauhaus, of Walter Gropius and Mies van der Rohe, eventually creating works with a balance between ancient and modern, innovation and tradition, revolution and conservation. The same philosophy is a feature of this furniture.

"I imagined a landscape of sophisticated domestic objects which interact thanks to the forms and high-quality craft manufacture. I aimed at the collection of an overall context, with a consistent style, in which each element is part of a dialogue."

The new collection by Matteo Nunziati explores the language of modernity, made up of research, harmony of form, crafted detailing and a coherence between materials and finishes.

ELEGANZA E INNOVAZIONE DI RUBELLI CASA

Rubelli Casa è la collezione di mobili e imbottiti, creata, prodotta e distribuita da Rubelli.

Lanciata nel 2015, negli anni la collezione si è arricchita di nuovi prodotti destinati in particolare all'area living e dining. Bellezza, eleganza senza tempo, comfort, atemporalità, dettagli sartoriali e scelte raffinate per finiture, textures e materiali esclusivi sono i segni distintivi di questa collezione che fin dall'inizio, per lo stile e il design proposto, ha rivendicato uno spazio tutto suo.

Una collezione italiana, sia nella creazione – ad oggi tutti i designer sono italiani - sia nella produzione, tutta rigorosamente made in Italy.

Le creazioni Rubelli Casa nascono da più mani e da differenti personalità. Di qui, un'offerta molto articolata ma sempre coerente e dalle diverse anime.

Quella razionalista di Luca Scacchetti, ispirata ai maestri del design milanese del secolo scorso, ma ingentilita con dettagli riconducibili al decorativismo veneziano.

Ne sono un esempio il Forcola Cabinet, il tavolo Schola Granda Flower, la scrivania Rio Novo desk, la poltrona Barbàcan e le poltroncine Canevin e Clintòn.

Quella spiccatamente contemporanea della collezione Cinecittà – disegnata dall' Architetto Marco Piva – giocata sull'utilizzo e sovrapposizioni di materiali e textures diverse, e caratterizzata da forme geometriche e linee slanciate per dare leggerezza ai prodotti. Come, ad esempio, i tavoli Rodolfo, i coffee table Fellini e Rossellini, i divani Lollo e Marcello, le poltroncine Silvana e Stefania.

Quella vintage di Studio Rubelli, che trova la massima espressione nei divani Palazzo e Triennale, nella panchetta Dadamaino, nelle sedie Ascari e Nuvolari. Pezzi che con il loro spirito vintage rievocano gli anni Cinquanta in un equilibrato mix di decorazione e design.

C'è poi l'anima innovativa delle creazioni dei giovani designer Nava+Arosio che, dopo aver disegnato per Rubelli l'originalissima poltrona tessile Pila-47, e il divano Domino, propongono la capsule collection Piano, una collezione giocata su elementi scultorei, ma al contempo "leggeri", capaci di creare effetti scenografici molto particolari.

La collezione più recente – creata da Matteo Nunziati – ha un'anima fortemente contemporanea ma allo stesso tempo equilibrata, coerente e lineare.

Di una classicità sottilmente densa di memoria perché capace di evocare un'idea di ordine, equilibrio, proporzione e armonia tra

le parti, amore per il dettaglio e sapienza costruttiva. Il divano componibile Asola e la poltrona Tela come la libreria Frame ne sono ottimi esempi.

Tutti i prodotti Rubelli Casa sono proposti in un'ampia gamma di finiture, in materiali pregiati - quali il marmo Calacatta Vagli, il noce, l'ebano, l'eucalipto pomelé – e spesso innovativi. Tra questi il Damantio®, materiale creato e brevettato da Rubelli nel 2017.

Perfetta sintesi tra know how tessile e innovazione tecnologica, il Damantio® trova applicazione come top nei coffee table Greta e Rossellini dell'architetto Piva, come finitura nelle cornici degli specchi Gillo, ma anche come "unico" materiale nel tavolino Peggy di Studio Rubelli.

Il Gruppo Rubelli offre inoltre l'opportunità di arredare la propria casa con veri e propri pezzi unici: ciascun cliente può infatti selezionare dalla vastissima gamma di tessuti Rubelli i rivestimenti tessili dei propri imbottiti.

Rubelli Casa è quello che non c'era: una nuova via nel mondo dell'arredo e del decor.

Rubelli nasce nel 1889 e fin dall'inizio riesce in modo straordinario a tradurre in prodotto industriale la ricchissima tradizione tessile veneziana fatta di damaschi, broccati, velluti e sete preziose. Si rinnova coinvolgendo designer come Gio Ponti, Roberta di Camerino e più recentemente Giorgio Armani e Peter Marino. Oggi è considerata una delle aziende di riferimento nella produzione del tessile per la casa.

La continua evoluzione, l'idea di mettersi continuamente in discussione per affrontare il mutare del tempo è tipica dell'arte e del design italiano. Con la nuova collezione Rubelli Casa, Matteo Nunziati ha compreso la vera anima dell'azienda. Scavando nella tradizione e nelle sue peculiarità straordinarie, ha scoperto una storia complessa che ha radici antiche.

"L'aspetto che più mi ha colpito è che Rubelli è riuscita negli anni a rinnovare continuamente la sua tradizione, mantenendo fede alla sua identità e allo stesso tempo guardando avanti."

L'ispirazione è nata dall'arredo delle dimore alto borghesi milanesi degli anni Trenta come Villa Necchi Campiglio disegnata da Piero Portaluppi e dalle opere di Gio Ponti e Guglielmo Ulrich degli stessi anni. Autori che facevano parte del movimento culturale ed artistico chiamato "Novecento", nato a Milano alla fine del 1922, che ha come supremo riferimento l'antichità classica, la purezza delle forme e l'armonia nella composizione e che viene contaminato dalla grande rivoluzione modernista e razionalista mittel europea della Bauhaus, di Walter Gropius e Mies van der Rohe, finendo per generare opere che creano un equilibrio tra antico e moderno, tra innovazione e tradizione, tra rivoluzione e conservazione. La stessa filosofia che caratterizza questi arredi. *"Ho immaginato un paesaggio di oggetti domestici ricercati, che dialogano tra loro grazie alla compostezza delle forme e ad un'esecuzione di alta qualità artigianale."* Afferma Matteo Nunziati *"Ho puntato alla collezione di un ambiente complessivo, dallo stile omogeneo, in cui ogni elemento è parte di un dialogo."*

Esplora il linguaggio di modernità, fatto di ricerca, armonia formale, cura del dettaglio, coerenza tra materiali e finiture: la nuova collezione firmata Matteo Nunziati.

2020



Lookbook new products

| | |
|----------------------|---------------|
| AGO | <i>pag 27</i> |
| ASOLA SOFA | <i>pag 24</i> |
| ASOLA COFFEE TABLE | <i>pag 9</i> |
| ASOLA POUF | <i>pag 26</i> |
| BOULE LAMP | <i>pag 40</i> |
| FRAME BOOKCASE | <i>pag 28</i> |
| PILA LOUNGE | <i>pag 34</i> |
| PILA POUF | <i>pag 48</i> |
| PIANO RECTANGULAR | <i>pag 44</i> |
| PIQUÉ LOW | <i>pag 30</i> |
| PIQUÉ TALL | <i>pag 32</i> |
| STAGE | <i>pag 30</i> |
| TELA | <i>pag 10</i> |
| TWILL | <i>pag 20</i> |
| VELOUR SOFA | <i>pag 19</i> |
| VELOUR ARMCHAIR | <i>pag 21</i> |
| VELOUR CHAISE LONGUE | <i>pag 42</i> |







CLOCKWISE: Tela armchair in Moka stain ashwood and Crochet Madreperla fabric, Ago side table with leather folder, Asola sofa in Crochet Madreperla and Asola coffee table with Calacatta Vagli top.

OPPOSITE: Piqué cabinet with textile panel and Asola sofa.
IN SENSO ORARIO: Tela poltrona in frassino tinto Moka e tessuto Crochet Madreperla, Ago tavolino con tasca portariviste in pelle, Asola divano in tessuto Crochet Madreperla e Asola tavolino con piano in marmo Calacatta Vagli. PAGINA A FIANCO: Piqué madia con ante in tessuto e Asola divano.



Tela is an armchair in which form and the materials used (wood and fabric here) interact closely and inextricably together to strengthen and enhance each other.

High manufacturing skill is offset by best use of the fabric. The structure of the seat is in hardwood. Tela is available in two wood types – natural walnut which enhances its elegance and radiance, or mocha stained ash which underscores its sinuous appearance.

All the constructional details, such as the original joint between back, legs and arms upholstered in fabric, like the other joints, slightly rounded, were designed to highlight the total craft quality of this piece.

The distinctive feature of this armchair is to be sought in the fabric which makes up the seat and back and is bonded to the leather, a totally new technical solution which, by adding consistency to the fabric, turns it into a structural element without however depriving it of its elegance and intrinsic luxury. Tela is the manifestation of lightweight solidity. A highly successful oxymoron.

TELA COD. A12121

Tela è una poltrona in cui forma e materiali impiegati (nello specifico legno e tessuto), in uno stretto e imprescindibile dialogo fra loro si rafforzano e si esaltano reciprocamente.

Ad una grande sapienza costruttiva fa da contrappunto la massima valorizzazione del tessuto. La struttura della seduta è realizzata in legno massello. Tela viene proposta in due essenze: noce naturale, che ne esalta eleganza e luminosità, oppure frassino tinto moka che ne mette in rilievo la sinuosità.

Tutti i dettagli costruttivi, come l'originale giunto tra schienale, gambe e braccioli rivestito in tessuto, così come le altre giunzioni, leggermente arrotondate, sono stati studiati per esaltare l'assoluta artigianalità di questo pezzo.

Il tratto distintivo di questa poltrona va ricercato nel tessuto che costituisce seduta e schienale e che viene accoppiato al cuoio: una soluzione tecnica assolutamente inedita che, conferendo consistenza al tessuto, ne fa un elemento strutturale senza però privarlo della sua eleganza e della sua preziosità intrinseca.

Tela è espressione di una solidità leggera. Un ossimoro ben riuscito.

FABRIC CROCHET AVORIO





Piqué cabinet with doors upholstered in customised fabric with an exclusive 3D diamond decoration and embellished with a metal frame with polished black nickel finish.

Madia Piqué con ante rivestite in tessuto personalizzato con un'inedita decorazione tridimensionale a rombi e impreziosite da una cornice metallica con finitura nickel nero lucido.



PIANO TABLE

ASCARI CHAIR

A VERY SOLID AND HIGHLY SOPHISTICATED TABLE, WITH NEW FINISHES ALSO AVAILABLE FOR THE SLIM TOP THAT SEEMS SIMPLY TO REST LIGHTLY ON THE FRAME.











Velour is a seating range featuring generous, soft and inviting shapes. The curved shell which shapes the back and arms is in bent wood and can be upholstered in leather or fabric. The fabric details, such as the piping which enhances the curved outline of the seats or the double and single seams framing the shapes, underline the strongly crafted and sophisticated workmanship involved in the details.

VELOUR COD.A12125

Velour è un sistema di sedute caratterizzato da forme generose, morbide ed accoglienti. La scocca curva, che definisce lo schienale e i braccioli, è realizzata in legno curvato e può essere rivestita in cuoio o tessuto. I dettagli tessili - come il piping che esalta il profilo curvo delle sedute oppure le cuciture doppie e singole che incorniciano le forme - sottolineano la fattura altamente artigianale e ricercata dei dettagli.

FABRIC VELVETY GRIGIO



ON THE PAGES: Velour armchair in Nuance du sable
Blu gris fabric and Twill pouf in Nuance du sable
Ardoise fabric and wooden box in Moka stain
ashwood.

IN QUESTE PAGINE: Velour poltrona in tessuto
Nuance du sable Blu gris e Twill pouf in tessuto
Nuance du sable Ardesia e piano in frassino tinto
Moka.







Asola is a range of seating, low tables and poufs featuring a fabric-covered base supported by feet in mocha stained ash. The broad flexibility of the modules allows the creation of different compositions that are suitable for furnishing all spaces. For the sofa the seat cushions, arms and back are linear and minimalist, yet at the same time soft and enveloping. The buttonhole with the chromed button is the sophisticated and sartorial detail that references the company's great craft capabilities and textile calling. The low tables, in line with the structure of the sofas, also have a base upholstered in fabric which rests on feet in ash. The top is available in different materials. A cushion attached to the base can convert them into poufs, making them versatile and functional items, coherent in their elegance. Also available in the version with aligned or staggered cushions and trays. Asola is... an island, a safe harbour, elegant and functional.

ASOLA COD.A12132

Asola è un sistema di sedute, tavoli bassi e pouf caratterizzati da una base sollevata da terra rivestita in tessuto e retta da piedini in frassino tinto moka. L'ampia flessibilità dei moduli permette di creare diverse composizioni adatte ad arredare gli spazi più diversi. Lineari ed essenziali, i cuscini della seduta, i braccioli e lo schienale del divano sono morbidi ed avvolgenti. Decisamente ricercato, il dettaglio sartoriale dell'asola con bottone evoca la grande sapienza artigianale e rimanda alla vocazione tessile dell'azienda. I tavoli bassi, in linea con la struttura dei divani, presentano anch'essi una base rivestita di tessuto che poggia su piedini in frassino. Il top è disponibile in materiali diversi. Un cuscino unico fissato alla base può trasformare il modulo in pouf. Disponibile anche nella versione con cuscini e vassoi allineati o sfalsati. Asola è... un'isola: un approdo sicuro, elegante e funzionale.

FABRIC CROCHET MADREPERLA





CLOCKWISE: Asola sofa and Contrada Trio coffee table with Damantio® top, Asola sofa and Ago side table with leather folder. OPPOSITE: Tela armchair in Moka stain ashwood and Crochet Madreperla fabric and back in brown leather, Asola pouf with split shelves in Chocolate Walnut.

IN SENSO ORARIO: Asola divano e Contrada Trio tavolini con piano in Damantio®, Asola divano e Ago tavolino con tasca portariviste in pelle. PAGINA A FIANCO: Tela poltrona in frassino tinto Moka e tessuto Crochet Madreperla con schienale in pelle marrone e Asola pouf con piano in Noce Cioccolato.





A dark wood shelving unit with a central panel featuring a textured, geometric pattern. The unit has five shelves. The top shelf holds a blue and white vase. The second shelf holds two red vases and a book titled "CHANEL". The third shelf holds a red jar and a stack of books. The fourth shelf holds a white bowl and a stack of books. The bottom shelf is empty.

A blue and white ceramic vase with a floral pattern, sitting on the top shelf of the shelving unit.

Two red ceramic vases with a glossy finish, sitting on the second shelf of the shelving unit.

A book titled "CHANEL" by Karl Lagerfeld, sitting on the second shelf of the shelving unit.

A red ceramic jar with a black lid, sitting on the third shelf of the shelving unit.

A stack of books, sitting on the third shelf of the shelving unit.

A white ceramic bowl, sitting on the fourth shelf of the shelving unit.

A stack of books, sitting on the fourth shelf of the shelving unit.

A potted plant with long, thin leaves, located on the right side of the image.

A modern chair with a dark wood frame and a light-colored seat, located in the bottom right corner of the image.

Frame is a bookcase inspired by the designs of Venice architect Carlo Scarpa, in whose works all the details are carefully researched and masterfully produced. A metallic frame in gloss black nickel runs around the outline of each single component of this furniture item, making it highly sophisticated and exclusive in its contemporary style.

The materials used are suited to a personalised interpretation of the product, always ensuring strong aesthetic connotations. The shelves are in wood (Chocolate Walnut and Natural Walnut), while the external side panels are covered in fabric.

LED lights are included as options to enhance the 3D nature of the back and the objects on the shelves and to make this bookcase an even more magical and alluring furniture item.

NEXT PAGE: Piqué is a range of storage units. The reference is a link to the Venetian architect Carlo Scarpa, in whose works all the details are perfectly studied and masterfully produced. The doors can be in wood (Chocolate Walnut and Natural Walnut) or upholstered in fabric. They are embellished with a metal frame with polished black nickel finish. The shapes are understated yet there is richness coming from the elaborately produced proportions, researched in depth, and the skilfully produced details in metal, fabric and wood.

The variety of materials and finishes that live side by side, enhancing each other, allow designers to use this piece to furnish different areas of the home.

Frame è una libreria ispirata ai progetti dell'architetto veneziano Carlo Scarpa, nelle cui opere tutti i dettagli sono accuratamente studiati e magistralmente realizzati. Una cornice metallica in nickel nero lucido corre intorno al perimetro di ogni singolo componente di questo elemento di arredo, rendendolo fortemente ricercato ed esclusivo nella sua contemporaneità. I materiali utilizzati si prestano ad una interpretazione personalizzata del prodotto garantendo sempre una forte connotazione estetica.

Gli scaffali sono realizzati in legno (Noce Cioccolato e Noce Naturale), i fianchi esterni sono rivestiti in tessuto. Per esaltare sia la tridimensionalità dello schienale che gli oggetti appoggiati sugli scaffali sono state previste delle luci opzionali a tecnologia Led, così da fare di questa libreria un complemento di arredo ancor più magico e seducente.

PAGINA SUCCESSIVA: Piqué è un sistema di mobili contenitori. Il riferimento è legato all'architetto veneziano Carlo Scarpa, nelle cui opere tutti i dettagli sono perfettamente studiati e magistralmente realizzati. Le ante possono essere realizzate in legno (Noce Cioccolato e Noce Naturale) oppure rivestite in tessuto. Le impreziosisce una cornice metallica con finitura polished black nickel. Le forme sono essenziali, ma la ricchezza viene trasmessa dalla elaborata realizzazione delle proporzioni approfonditamente studiate e dei dettagli di metallo, tessuto e legno, magistralmente realizzati.

La varietà di materiali e finiture che convivono tra di loro esaltandosi reciprocamente permettono al progettista di utilizzare questo pezzo per arredare differenti scenari domestici.

FRAME BOOKCASE COD.A16025

3D PANEL WITH DIVA SHANTUNG FABRIC









PIQUÉ

CABINET

UNDERSTATED SHAPES, RICHLY SUMPTUOUS,
PROPORTIONS WITH CAREFULLY
DESIGNED DETAILS IN METAL, FABRIC AND
WOOD, MASTERFULLY MANUFACTURED.





Pila is a “family” of fabric-covered armchairs, including two models in different dimensions and a pouf. All textile and with an adaptable seat, Pila-47 is entirely hand-made and can be covered with the Rubelli fabrics in collection.

Pila è una famiglia di poltrone che comprende due modelli di diverse dimensioni e un pouf. Completamente in tessuto e modulabile nella seduta, la poltrona Pila-47 è fatta a mano e può essere declinata con i tessuti Rubelli presenti in collezione.









CLOCKWISE: Twill pouf in Nuance du sable Poudre fabric and wooden box in Moka stain ashwood, Piqué cabinet low, Contrada tables and Velour sofa in Nuance du sable Beige Rosé.

IN SENSO ORARIO: Twill pouf in tessuto Nuance du sable Poudre e piano in frassino tinto Moka, Piqué madia bassa, Contrada tavolini e Velour divano in Nuance du sable Beige Rosé.





Floor lamp Boule with hand-engraved glass so as to reference the typical decoration and texture of a Rubelli fabric.

Lampada da terra Boule con vetro inciso manualmente, così da richiamare la texture e la decorazione tipiche di un tessuto Rubelli.



VELOUR

CHAISE LONGUE

GENEROUS, SOFT, WELCOMING SHAPES
HEIGHTEN THE STRONGLY CRAFTED
AND SOPHISTICATED MANUFACTURE
OF THE DETAILS.











ON THE PAGES: Piano rectangular table in Chocolate Walnut and Anita arm chair in Fabthirty rosa fabric.

IN QUESTE PAGINE: Piano tavolo rettangolare in Noce Cioccolato e Anita poltrona rivestita in tessuto Fabthirty rosa.





PILA LOUNGE

PILA POUF

AN ORIGINAL AND EXCLUSIVE ALL-TEXTILE ARMCHAIR, THE SEAT OF PILA CAN BE ADJUSTED AND ADAPTED TO EVERY POSTURE.



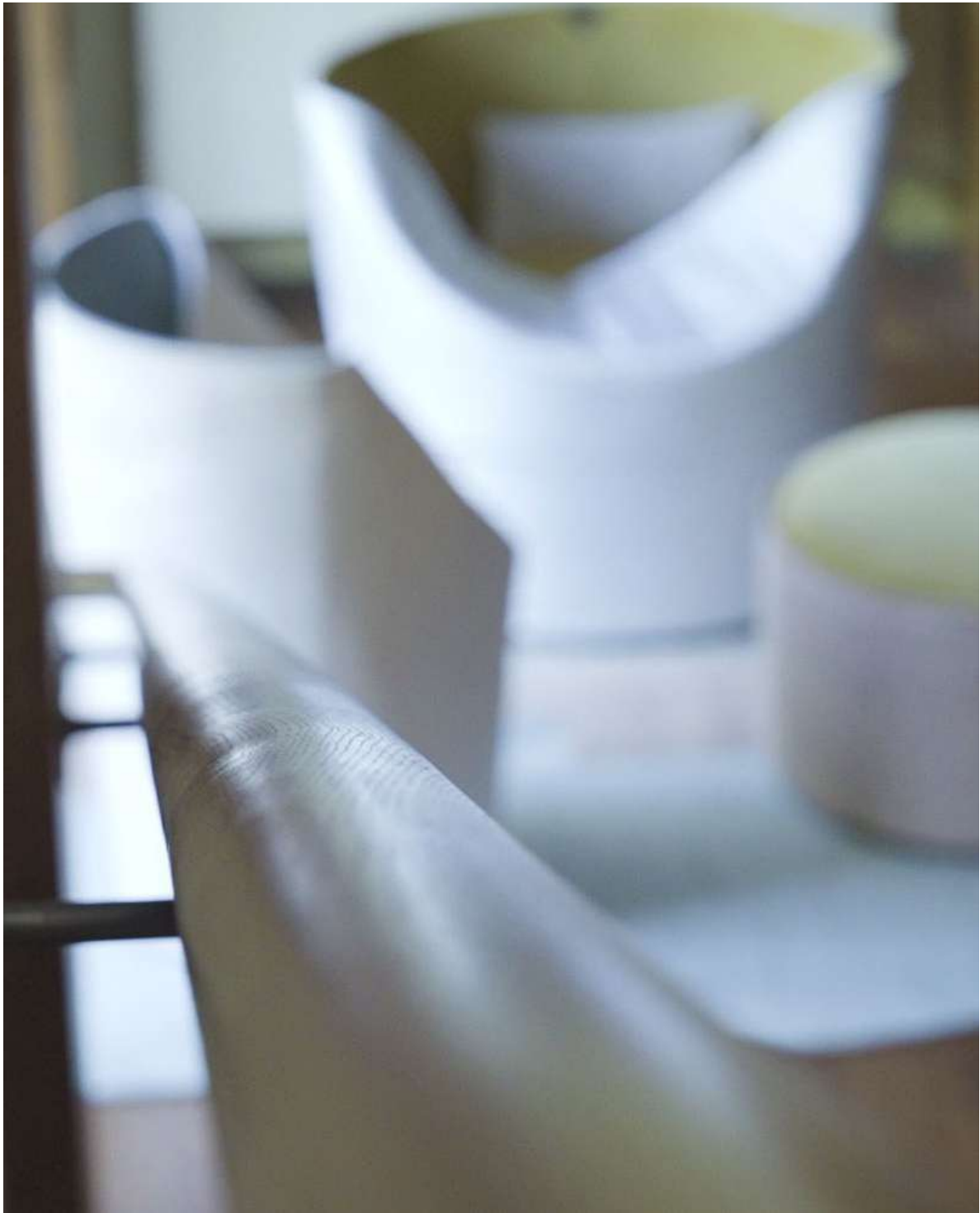

ANTHOLOGY

ANTHOLOGY

Sofas & Armchairs

| | |
|--------------------|---------------|
| ASOLA SOFA | <i>pag 54</i> |
| ASOLA MODULAR SOFA | <i>pag 58</i> |
| ASOLA POUF | <i>pag 60</i> |
| BARBACÀN | <i>pag 62</i> |
| CANEVÌN | <i>pag 64</i> |
| CLINTÓN | <i>pag 66</i> |
| CORTE NOVA III | <i>pag 68</i> |
| DADAMAINO | <i>pag 72</i> |
| DOMINO SOFA | <i>pag 74</i> |
| DOMINO SOFA PLUS | <i>pag 79</i> |
| DOMINO CHAIR | <i>pag 80</i> |
| LOLLO SOFA | <i>pag 82</i> |
| LOLLO TUB CHAIR | <i>pag 88</i> |

| | |
|-----------------------|----------------|
| MARCELLO MODULAR SOFA | <i>pag 90</i> |
| PALAZZO | <i>pag 96</i> |
| PILA - 47 | <i>pag 98</i> |
| PILA LOUNGE | <i>pag 102</i> |
| PILA POUF | <i>pag 106</i> |
| SILVANA | <i>pag 108</i> |
| SILVANA LOUNGE | <i>pag 110</i> |
| SOPHIA | <i>pag 112</i> |
| SQUERARÒL | <i>pag 114</i> |
| STEFANIA CLUB CHAIR | <i>pag 116</i> |
| TELA | <i>pag 118</i> |
| TRIENNALE SOFA | <i>pag 120</i> |
| TRIENNALE LOUNGE | <i>pag 126</i> |
| TWILL | <i>pag 128</i> |
| VELOUR SOFA | <i>pag 130</i> |
| VELOUR CHAISE LONGUE | <i>pag 135</i> |
| VELOUR ARMCHAIR | <i>pag 136</i> |

Chairs & Tables

| | |
|----------------------|----------------|
| ANITA | <i>pag 138</i> |
| ASCARI | <i>pag 140</i> |
| B.B. | <i>pag 142</i> |
| NUVOLARI | <i>pag 144</i> |
| VIRNA | <i>pag 146</i> |
| PIANO RECTANGULAR | <i>pag 148</i> |
| PIANO ROUND | <i>pag 152</i> |
| RODOLFO OVAL | <i>pag 154</i> |
| RODOLFO ROUND | <i>pag 156</i> |
| SCHOLA GRANDA CARD | <i>pag 158</i> |
| SCHOLA GRANDA FLOWER | <i>pag 159</i> |

| | | |
|----------------------|---------------------------------|----------------|
| <i>Coffee tables</i> | A G O | <i>pag 162</i> |
| | A S O L A C O F F E E T A B L E | <i>pag 164</i> |
| | B A Ù T A | <i>pag 166</i> |
| | C A L L E S T E L L A | <i>pag 168</i> |
| | C O N T R A D A T R I O | <i>pag 170</i> |
| | F E L L I N I | <i>pag 172</i> |
| | G R E T A T R I O | <i>pag 176</i> |
| | P A B L O | <i>pag 178</i> |
| | P E G G Y | <i>pag 180</i> |
| | P I A N O L A R G E | <i>pag 182</i> |
| | P I A N O S M A L L | <i>pag 184</i> |
| | R O S S E L L I N I | <i>pag 186</i> |
| | T E L È R | <i>pag 188</i> |

| | | |
|--------------------------------|-----------------------------------|----------------|
| <i>Cabinets & Consoles</i> | F Ò R C O L A B A R C A B I N E T | <i>pag 190</i> |
| | F R A M E B O O K C A S E | <i>pag 192</i> |
| | P I Q U É L O W | <i>pag 194</i> |
| | P I Q U É T A L L | <i>pag 196</i> |
| | R Ì O N O V O | <i>pag 198</i> |
| | R Ì O T E R Á | <i>pag 200</i> |
| | S C H O L È T A | <i>pag 202</i> |
| | S C H O L È T A L U X U R Y | <i>pag 204</i> |

| | | |
|--------------------------------|-----------------------|----------------|
| <i>Lamps & Accessories</i> | B O U L E L A M P | <i>pag 206</i> |
| | G I L L O L A R G E | <i>pag 208</i> |
| | G I L L O S Q U A R E | <i>pag 210</i> |
| | S T A G E | <i>pag 212</i> |
| | W A L L A R T | <i>pag 214</i> |
| | L I N G O T T O | <i>pag 216</i> |



Asola: A VERSATILE SEATING SYSTEM
THAT REINTERPRETS TRADITIONAL
TEXTILE ELEMENTS, SUCH AS THE
TAILORING DETAIL OF THE BUTTONHOLE
WITH BUTTON, COMBINING THEM
WITH A SLEEK, CONTROLLED SUPPORT
STRUCTURE THAT SLOTS SMOOTHLY
INTO THE CONTEMPORARY IDIOM.

Asola: un sistema di sedute trasversale che riprende elementi della tradizione tessile, come il dettaglio sartoriale dell'asola con bottone, associandoli a una struttura di sostegno fine e rigorosa che si inserisce nel linguaggio contemporaneo.

ASOLA SOFA



Design M A T T E O N U N Z I A T I
Cod. A 1 2 1 3 0 *Fabric* C R O C H E T M A D R E P E R L A

Asola is a range of seating, low tables and poufs featuring a fabric-covered base supported by feet in mocha stained ash. The broad flexibility of the modules allows the creation of different compositions that are suitable for furnishing all spaces. For the sofa the seat cushions, arms and back are linear and minimalist, yet at the same time soft and enveloping. The buttonhole with the chromed button is the sophisticated and sartorial detail that references the company's great craft capabilities and textile calling.

Other finishings: legs 38.moka stain ashwood.

Asola è un sistema di sedute, tavoli bassi e pouf caratterizzati da una base sollevata da terra rivestita in tessuto e retta da piedini in frassino tinto moka. L'ampia flessibilità dei moduli permette di creare diverse composizioni adatte ad arredare gli spazi più diversi. Lineari ed essenziali, i cuscini della seduta, i braccioli e lo schienale del divano sono morbidi ed avvolgenti. Decisamente ricercato, il dettaglio sartoriale dell'asola con bottone evoca la grande sapienza artigianale e rimanda alla vocazione tessile dell'azienda.

Altre finiture: piedi 38.frassino tinto moka.

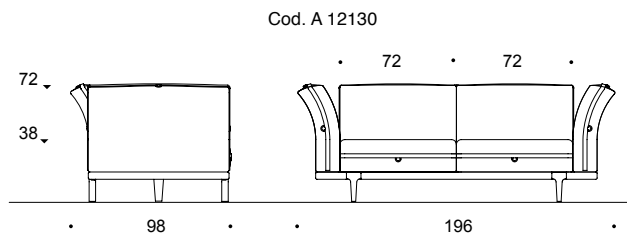

ASOLA SOFA PLUS



Design MATTEO NUNZIATI
Cod. A 1 2 1 2 8 *Fabric* CROCHET MADREPERLA

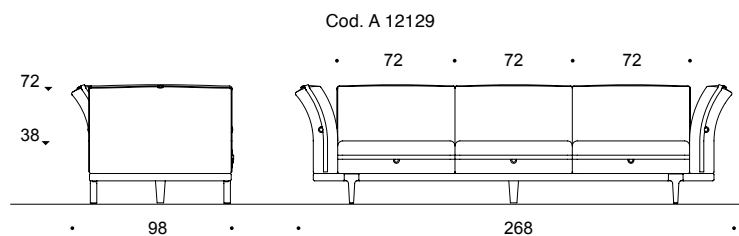
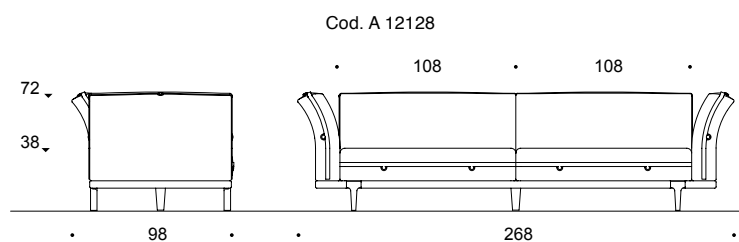

ASOLA MODULAR SOFA



Design MATTEO NUNZIATI
Fabric CROCHET AVORIO

Cod. A 12131 *

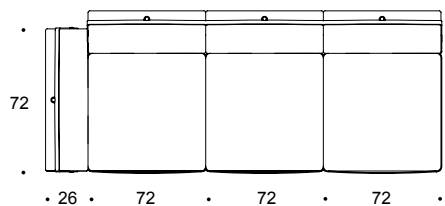

Cod. A 12133 *

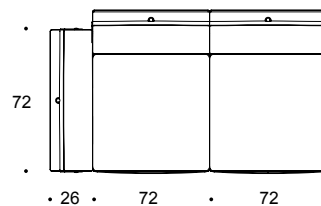

Cod. A 12132 *

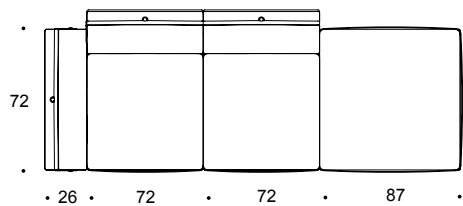

Cod. A 12134 *

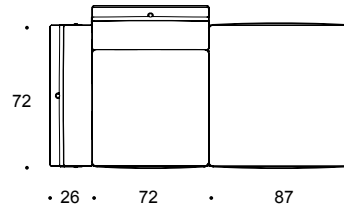

Cod. A 12135 *

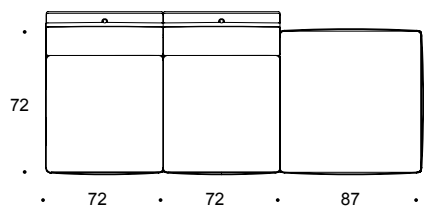

Cod. A 12136 *

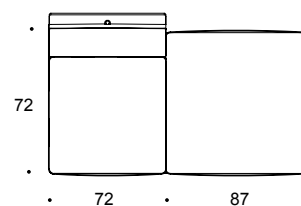

* available versions right and left / versioni disponibile dx e sx



ASOLA POUF



Design M A T T E O N U N Z I A T I

Cod. A 1 2 1 3 7 / A 1 2 1 3 8

Fabric C R O C H E T A V O R I O

A cushion attached to the base can convert them into poufs, making them versatile and functional items, coherent in their elegance.

Un cuscino unico fissato alla base può trasformare il modulo in pouf. Disponibile anche nella versione con cuscini e vassoi allineati o sfalsati.

Other finishings: legs 38.moka stain ashwood, tray 38.moka stain ashwood, 73.Calacatta Vagli marble, 74.Emperador dark marble, 90.bronze Damantio®, 92.silver Damantio®.

Altre finiture: piedi 38.frassino tinto moka, vassoio 38.frassino tinto moka, 73.marmo Calacatta Vagli, 74.marmo Emperador dark, 90.Damantio® bronzo, 92.Damantio® argento.

Cod. A 12137

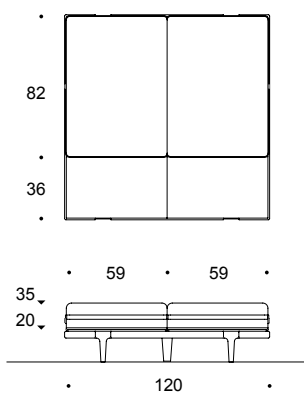

Cod. A 12138

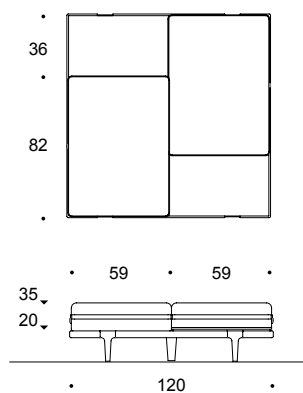

Cod. A 12139

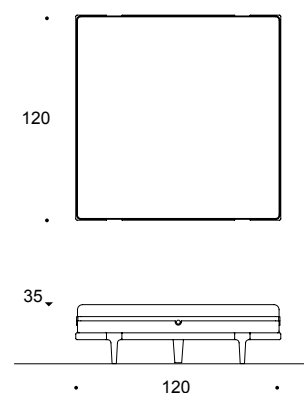



BARBÀCAN



Design L U C A S C A C C H E T T I
Cod. A 1 2 0 1 5 *Fabric* F I F T H A V E N U E B L U

The Barbàcan armchair was designed for relaxation and is upholstered with polyurethane foam in multiple densities. The high back, totally detached from the seat, makes it a modern alternative to the classic bergère. The frame is in solid wood finished in dark wenge. Barbàcan can also be personalised with different fabric or leather.

Finishing: 01.stained in dark wenge.

Barbàcan nasce come poltrona da relax accogliente ed imbottita con poliuretano espanso a densità differenziate. Lo schienale alto e completamente staccato della seduta la rendono una moderna alternativa alla classica bergère. La struttura è realizzata in legno massello.

Finitura: 01.tinto wengè scuro.

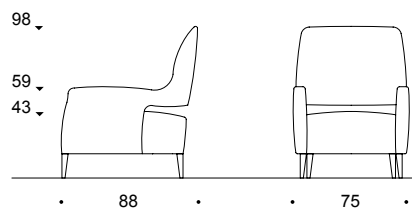



CANEVIN



Design L U C A S C A C C H E T T I
Cod. A 1 2 0 1 1 *Fabric* R E L O A D E D C H A R T R E U S E

Canevin is distinctive for its linear and elegant design. The chair has got fully upholstered wood frame over a metal base which is available in multiple finishes: bronze, satin brass, polished black nickel and satin nickel. Designed by Luca Scacchetti, it can be covered in the vast range of Rubelli fabrics or leather.

Other finishes: 51.bronze finish, 54.polished black nickel finish, 55.satin nickel, 56.satin brass finish.

Canevin si distingue per il design lineare ed elegante. Completamente imbottita, presenta seduta e schienale con struttura in legno e base metallica disponibile in finitura bronzo, ottone satinato, nickel nero lucido e nickel satinato. Disegnata da Luca Scacchetti, può essere rivestita a piacimento con la vasta gamma di tessuti o pelli Rubelli.

Altre finiture: 51.finitura bronzo, 54.finitura nickel nero lucido, 55.finitura nickel satinato, 56.finitura ottone satinato.

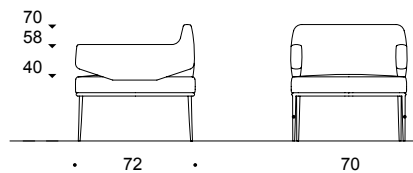



CLINTÓN



Design L U C A S C A C C H E T T I
Cod. A 1 2 0 0 9 *Fabric* T A I D A I A V O R I O

Clintón is the iconic armchair in the Rubelli Casa collection. Resting on a slim metal base, it is available in various satin and gloss finishes. Wraparound and sleek, and with a shaped of the back, Clintón pairs nicely with the Palazzo sofa.

Other finishings: 51.bronze finish, 54.polished black nickel finish, 55.satin nickel, 56.satin brass finish.

Clintón è la poltrona iconica della collezione Rubelli Casa. Poggiata a una snella base in metallo, è disponibile in diverse finiture satinare e lucide. Avvolgente e sinuosa, il morbido movimento sullo schienale la rende particolarmente adatta in abbinata con il divano Palazzo.

Altre finiture: 51.finitura bronzo, 54.finitura nickel nero lucido, 55.finitura nickel satinato, 56.finitura ottone satinato.

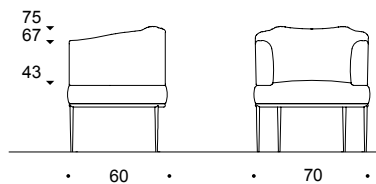



CORTE NOVA III



Design L U C A S C A C C H E T T I
Cod. A 1 2 0 7 9 *Fabric* P L U T O N E A V O R I O

Corte Nova is an uncompromising three-seater sofa and among the most contemporary in the collection. The rigid metal base is softened by a decorative leather trim which frames the seat and the small optional shelf compartments which can be placed as preferred on one or both sides of the sofa. Designed by Luca Scacchetti, it can be covered in the vast range of Rubelli fabrics.

Other finishings: 53.satin steel finish, 54.polished black nickel finish.

Corte Nova è un divano tre posti rigoroso ed il più contemporaneo della collezione. La rigida base di metallo viene ammorbidita da un profilo decorativo in pelle che incornicia la seduta e i vani portaoggetti opzionali, che possono essere disposti a piacimento su uno o entrambi i lati del divano. Disegnato da Luca Scacchetti, può essere rivestito con la vasta gamma di tessuti Rubelli.

Altre finiture: 53.finitura acciaio satinato, 54.finitura nickel nero lucido.

shown with two shelves option

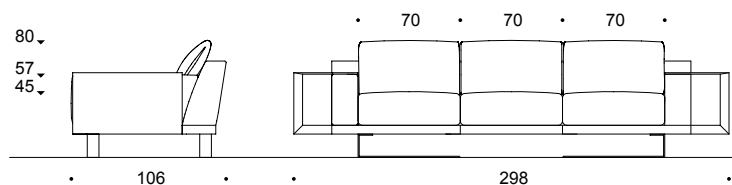

shown with one right side shelf option

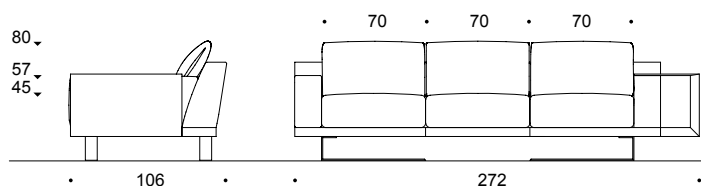



Design L U C A S C A C C H E T T I
Cod. A 1 2 0 7 9 *Fabric* P L U T O N E A V O R I O

standard sofa (no shelves)

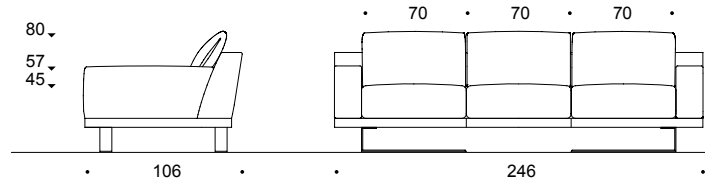



Corte Nova Sofa III (Plutone, avorio),
Telèr Coffee Table Square, Telèr Side
Table Tall and Small with Damantio®
bronze top.



DADAMAINO



Design STUDIO RUBELLI

Cod. A 1 2 1 0 3 Fabric VANITY LAGUNA Top OMBRA LAGUNA

Dadamaino was an exponent of the Milanese artistic avant-garde in the 1950s. Dadamaino Bench is versatile and easy to use. The slim, tapering legs, like those of the Palazzo sofa already in the collection, make it even more elegant and streamlined. The padded part, a lightweight capitonné with contemporary restyling, rests on a rigid and slightly trapezoidal fabric-covered base. The strength of Dadamaino, which vaguely references Fifties style, lies in the use of two fabrics - silk for the rigid part and velvet for the padding.

Other finishings: 51.bronze finish, 54.polished black nickel finish, 55.satin nickel, 56.satin brass finish.

Dadamaino era una esponente dell'avanguardia artistica milanese negli anni '50. La panchetta Dadamaino è versatile e di facile impiego. Le gambe sottili e affusolate - come quelle del Palazzo Sofa, già in collezione - contribuiscono a renderla ancora più elegante e slanciata. La parte imbottita, un leggero capitonné riletto in chiave contemporanea, poggia su una "base" rigida, leggermente trapezoidale e rivestita in tessuto. Dadamaino, che rievoca vagamente lo stile anni '50, ha il suo punto di forza nell'utilizzo di due tessuti: seta per la parte rigida e velluto per il capitonné.

Altre finiture: 51.finitura bronzo, 54.finitura nickel nero lucido, 55.finitura nickel satinato, 56.finitura ottone satinato.

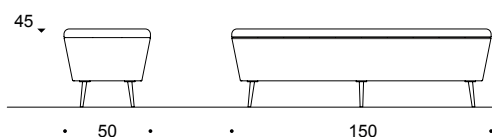





THE *Domino* RANGE IS THE REFINED
MANIFESTATION OF A WELL-
PROPORTIONED AESTHETIC FORM AND
A STRONG CONTEMPORARY STYLE
THAT IS ALSO EXTREMELY ELEGANT.

La serie *Domino* è l'espressione ricercata di una forma estetica equilibrata e di uno stile contemporaneo deciso, allo stesso tempo estremamente elegante.



Domino Sofa (Diso rame),
Contrada Trio with
Damantio® silver top



DOMINO SOFA



Design N A V A + A R O S I O
Cod. A 1 2 0 8 0 *Fabric* D I S O R A M E

Domino is a sofa which combines design and function with aesthetic and structural balance. Designed by the two young designers of Nava + Arosio Studio, Domino maintains equilibrium between contrasting lines: the geometric nature of the outer lines is offset by the sleek and soft inner lines. The sophisticated feet which support the frame add both stability and lightness. Upholstered with polyurethane foam with multiple densities, it is also available with a decorative fabric cover sewn onto the upper edge of the back.

Other finishings: 51.bronze finish, 54.polished black nickel finish, 55.satin nickel, 56.satin brass finish.

Domino è un divano che combina design e funzionalità in un'armonia estetica e strutturale. Disegnato dai due giovani designer di Nava + Arosio Studio, Domino è caratterizzato dall'equilibrio tra linee contrastanti: alla geometricità delle linee esterne si contrappone la sinuosità e morbidezza delle linee interne. I raffinati piedini che sorreggono la struttura conferiscono al contempo stabilità e leggerezza. Imbottito con poliuretano espanso a densità differenziate è anche disponibile con un reverse decorativo in tessuto cucito sul bordo superiore dello schienale.

Altre finiture: 51.finitura bronzo, 54.finitura nickel nero lucido, 55.finitura nickel satinato, 56.finitura ottone satinato.

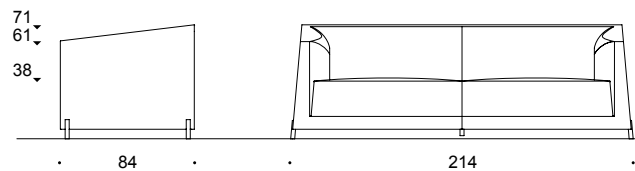

DOMINO SOFA PLUS



Design N A V A + A R O S I O
Cod. A 1 2 0 8 1 *Fabric* D I S O R A M E

Domino Sofa Plus is a sofa which combines design and function with aesthetic and structural balance. An elongated version of the original Domino, the Plus version ensures even greater comfort and blends in perfectly in spaces with large volumes. Designed by the duo Nava + Arosio Studio, it can be personalised by adding a decorative fabric cover sewn onto the upper edge of the back which can be turned over onto the front cushions.

Other finishing: 51.bronze finish, 54.polished black nickel finish, 55.satin nickel, 56.satin brass finish.

Domino Sofa Plus è un divano che combina design e funzionalità in un'armonia estetica e strutturale. Versione allungata dell'originario Domino, la variante Plus garantisce ancor più comfort e si inserisce perfettamente in ambienti dai volumi importanti. Disegnato dal duo Nava + Arosio Studio, è disponibile anche con una cover decorativa in tessuto cucita sul bordo superiore dello schienale che può essere ribaltata sui cuscini frontali.

Altre finiture: 51.finitura bronzo, 54.finitura nickel nero lucido, 55.finitura nickel satinato, 56.finitura ottone satinato.

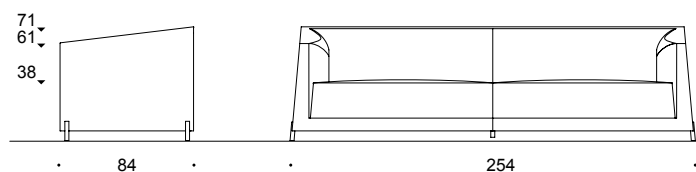

DOMINO CHAIR



Design NAVA + AROSIO

Cod. A 1 2 0 8 2

Fabric T W E E D C O U L E U R S N A V Y O R A N G E

An armchair in the range of the same name, Domino Chair was conceived by the young Milan designers Nava + Arosio to coordinate with the Domino Sofas. Like the sofa, the armchair also combines design and function, brings together tradition and modernity and plays with soft, geometric lines to add greater movement to the seat. With fabric or leather covers, the armchair is finished with metal legs and upholstered with differentiated density polyurethane foam.

Other finishings: 51.bronze finish, 54.polished black nickel finish, 55.satin nickel, 56.satin brass finish.

Poltrona della famiglia omonima, Domino Chair è stata concepita dai giovani designer milanesi Nava + Arosio. Come il divano, anche la poltrona combina design e funzionalità, unisce tradizione e modernità, gioca con linee geometriche e morbide per conferire maggiore dinamicità alla seduta. Rivestita in tessuto oppure pelle, la poltrona è finita con gambe in metallo e imbottita con poliuretano espanso a densità differenziate.

Altre finiture: 51.finitura bronzo, 54.finitura nickel nero lucido, 55.finitura nickel satinato, 56.finitura ottone satinato.

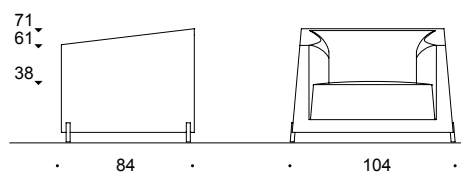





WITH A POWERFUL AESTHETIC AND
FUNCTIONAL APPEAL, THE SOFA
AND ARMCHAIR IN THE *Lollo* SERIES
ALLOW RELAXATION AREAS TO BE
CREATED THAT CAN BE ADAPTED
TO PERSONAL TASTE AND SPACE.

Dal forte appeal estetico e funzionale il divano e la poltrona della serie *Lollo* permettono di creare aree relax adattabili allo spazio e al gusto personali.



Lollo Sofa (Tweed Décoloré, moonscape),
Lollo Tub Chair (Domus, grigio, argento),
Sophia Pouf (Silent Movie, ardesia, Marcello,
pietra), Greta Trio Medium Table, Rossellini
Coffee Table Tall with Damantio® bronze top.



LOLLO SOFA



Design M A R C O P I V A

Cod. A 1 2 1 0 1

Fabric T W E E D D E C O L O R E M O O N S C A P E

Lollo Sofa - named after Gina Lollobrigida, the sexy Italian actress of the 1950s - is a two-seat sofa with simple and sophisticated lines, characterised by symmetrical proportions and the profile which outlines the enveloping shapes of the seat. The fabric, its key feature, serves to make it play various stage roles and use functions, exclusive and contemporary.

Other finishings: 51. bronze finish, 54. polished black nickel finish.

Lollo - vezzeggiativo di Gina Lollobrigida, seducente attrice degli anni '50 - è un divanetto a due posti dalle linee semplici e raffinate, caratterizzato da proporzioni armoniose e dal profilo che disegna le forme avvolgenti della seduta. Il tessuto, protagonista, si presta a fargli rivestire svariati ruoli scenici e di utilizzo, inediti e contemporanei.

Altre finiture: 51. finitura bronzo, 54. finitura nickel nero lucido.

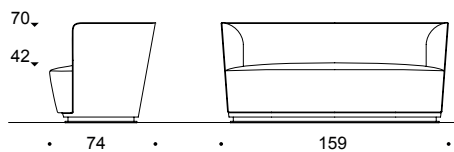



LOLLO TUB CHAIR



Design M A R C O P I V A
Cod. A 1 2 1 0 0 *Fabric* D O M U S A R G E N T O

Lollo Tub Chair is an armchair with low back and armrests. It is characterised by symmetrical proportions and the profile which outlines the enveloping shapes of the seat. The fabric, its key feature, serves to make it play various stage roles and use functions, exclusive and contemporary.

Other finishings: 51.bronze finish, 54.polished black nickel finish.

La poltrona Lollo è una seduta dalle linee semplici e raffinate, caratterizzata da armoniose proporzioni e dal profilo che disegna le forme avvolgenti della seduta. Il tessuto, protagonista, si presta a farle rivestire svariati ruoli scenici e di utilizzo, inediti e contemporanei.

Altre finiture: 51.finitura bronzo, 54.finitura nickel nero lucido.

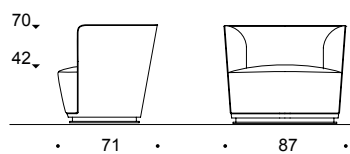



MARCELLO MODULAR SOFA



Design M A R C O P I V A
Cod. A 1 2 1 1 5 *Fabric* D I C K T R A C Y G R I G I O

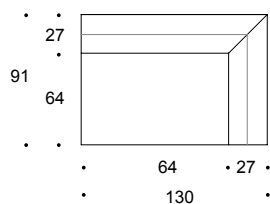

MARCELLO OTTOMAN



Design M A R C O P I V A
Cod. A 1 2 1 1 6 *Fabric* B R O D E R I E J A S P E R O U G E

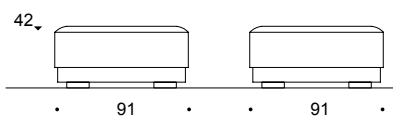





Marcello Sofa Modular
(Dick Tracy grigio), Piano
Coffee Tables Large and Small with
Calacatta marble top and natural
walnut top, Pablo Piano, Silvana
Lounge (Tricotage citron)



MARCELLO MODULAR SOFA



Design M A R C O P I V A
Fabric D I C K T R A C Y G R I G I O

Marcello Mastroianni. Suave and sophisticated. A versatile actor, an unforgettable star. The Marcello Modular Sofa combines aesthetic, function and maximum capacity for personalisation. Endless places are created by arranging a few modules side by side (right, left, middle, pouf and corner). This seating system can be used in home or contract spaces with a strong, refined personality.

The plays on colour contrasts between the various parts go to emphasise their shapes and characterise their look according to the various contexts in which the sofa is required to “play a part”.

Finishings: 01.stained in dark wenge.

Marcello Mastroianni. Elegante e raffinato. Versatile e Divo indimenticabile. Il divano modulare Marcello coniuga estetica, funzionalità e massima capacità di personalizzazione. Infiniti posti, grazie all'accostamento di pochi elementi (destro, sinistro, centrale, pouf e corner), questo sistema di sedute si inserisce negli ambienti residenziali o contract con un carattere deciso e raffinato.

I giochi di contrapposizione cromatica tra le diverse parti contribuiscono a enfatizzarne le forme e a caratterizzarne il look in funzione dei diversi ambienti che verrà chiamato a “interpretare”.

Finitura: 01.tinto wengè scuro.

Cod. A 12113

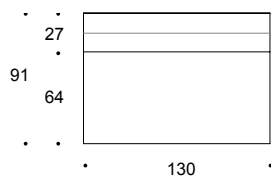

Cod. A 12114 *

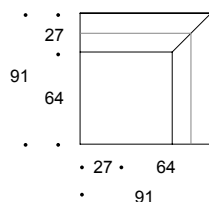

Cod. A 12115 *

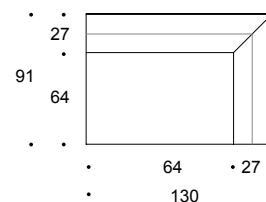

* available versions right and left / versioni disponibile dx e sx



PALAZZO



Design STUDIO RUBELLI

Cod. A 1 2 0 8 3 Fabric (on the left) VELVETFORTY BLU
Fabric (on the right) VELOURS DECONTRACTE OLIVE

Designed by Studio Rubelli, the Palazzo Sofa references the great Milan tradition of the Fifties.

Palazzo, a natural development on the theme built on in the first Rubelli Casa collection and with its sequence of curves on the back, pairs nicely with the iconic Clintón armchair. Visually lightweight and suspended on five metal rods, Palazzo is a comfortable and elegant sofa with a vintage soul, ideal for a formal living area but also for times of total relaxation.

Other finishings: 51.bronze finish, 54.polished black nickel finish, 55.satin nickel, 56.satin brass finish.

Progettato da Studio Rubelli, il divano Palazzo si rifà alla grande tradizione milanese degli anni '50.

Naturale evoluzione del filone sviluppato nella prima collezione Rubelli Casa, Palazzo, con il suo susseguirsi di curvature sullo schienale, ben si presta ad essere abbinato all'iconica poltrona Clintón. Visivamente leggero e sospeso su cinque steli metallici, Palazzo è un comodo ed elegante divano con un'anima vintage, ideale per un soggiorno formale ma anche come "rifugio" per una pausa di totale relax.

Altre finiture: 51.finitura bronzo, 54.finitura nickel nero lucido, 55.finitura nickel satinato, 56.finitura ottone satinato.

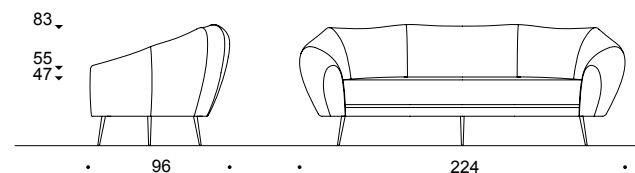





Pila: ORGANIC, SOFT AND SINUOUS SHAPES. THIS SERIES OF FLOOR-STANDING SEATS OFFERS A NEW MEANING OF COMFORT. ORIGINALITY SEEN IN THE TWO-TONE VERSIONS AND THOSE THAT MIX FABRICS, WITH HORIZONTAL AND VERTICAL SURFACES THAT INTERACT THROUGH NUANCES OF SHADES OR WITH STRONGER CONTRASTS.

Forme organiche, morbide e sinuose: *Pila*. Una nuova espressione del comfort si esprime in una serie di sedute “a terra”. Originali le soluzioni bicolori e quelle che prevedono abbinamento di tessuti, dove i piani orizzontali e quelli verticali dialogano attraverso tonalità in nuance oppure con contrasti pronunciati.

PILA - 47



Design NAVA + AROSIO
Cod. A 6 6 2 4 4 *Fabrics* TIEPOLO CREMA + CARLO ACQUA

An original all-textile armchair in which the true key feature is fabric. Created exclusively for Rubelli by the young designers Nava + Arosio, Pila-47 represents a new concept in seating.

Handmade throughout, it is capable of enhancing the potential of the fabric, regaining the idea of beauty of the materials themselves and of their natural lines.

Other finishings: base 00.black lacquer.

Pila-47 è un'originale ed esclusiva poltrona interamente tessile in cui il vero protagonista è il tessuto. Creata in esclusiva per Rubelli dai giovani designer Nava + Arosio, Pila-47 è modulabile nella seduta e perfettamente adattabile ad ogni postura. Completamente fatta a mano, è in grado di esaltare le potenzialità del tessuto, recuperando l'idea di bellezza dei materiali stessi e delle loro naturali linee.

Altre finiture: base 00.laccato nero.

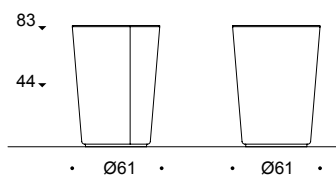



Design NAVA + AROSIO
Cod. A 6 6 2 4 4 *Model* BOLLICINE DAY
Fabrics BRAHMS MADREPERLA + GIOTTO MADREPERLA

PILA LOUNGE



Design NAVA + AROSIO

Cod. A 6 6 4 5 8 *Fabric* YOKO TIFFANY + OMBRA ACQUA

“We thought we should give Pila-47 an older sister”
(Nava+Arosio).

The seat in this new version changes sizes and shapes with the intent of creating a lounge chair in which comfort, design and amazement are distinctive features. The philosophy of the chair remains that of creating a seat in which the fabric is the absolute key feature and at the same time a product with greater flexibility of solutions thanks also to the installation of the new Pila Pouf which, coordinated with the chair, ensures a state of extreme comfort and relaxation. It can be used both with the Pila chairs and as a single element.

Other finishings: base 00.black lacquer.

“Ci sembrava doveroso regalare una sorella maggiore alla Pila 47” (Nava+Arosio).

In questa sua nuova versione la seduta cambia misure e forme con l'intento di andare a creare una poltrona lounge in cui comfort, design e stupore sono gli elementi distintivi. Lo spirito della poltrona resta quello di creare una seduta in cui il tessuto è assoluto protagonista, e nello stesso tempo un prodotto con maggiore flessibilità di soluzioni grazie anche all'inserimento del nuovo Pila Pouf che, coordinato alla poltrona, garantisce situazioni di estremo comfort e relax. Può essere utilizzato sia con le poltrone Pila che come singolo elemento.

Altre finiture: base 00.laccato nero.

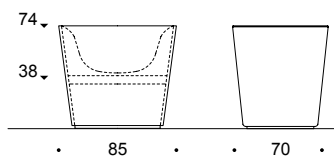



Design NAVA + AROSIO
Cod. A 6 6 4 5 8 *Cod.* A 6 6 4 5 9

PILA LOUNGE



Design NAVA + AROSIO
Cod. A 6 6 4 5 8 *Fabric* LUCENTE ICE



Design NAVA + AROSIO
Cod. A 6 6 4 5 8 *Fabrics* LUCENTE ICE + OMBRA ORO

PILA POUF



Design NAVA + AROSIO
Cod. A 6 6 4 5 9 *Fabric* CARLO GIADA + OMBRA CREMA

A textile pouf with discreet lines yet featuring sartorial details that echo the stitching and double piping in the Pila-47 collection.

Other finishings: base 00.black lacquer.

Un pouf tessile dalle linee sobrie ma caratterizzato da dettagli sartoriali che riprendono le cuciture e il doppio piping della collezione Pila-47.

Altre finiture: base 00.laccato nero.

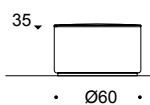



Design NAVA + AROSIO
Cod. A 6 6 4 5 9 *Fabrics* CARLO INCARNATO + OMBRA ORO

SILVANA



Design M A R C O P I V A

Cod. A 1 2 1 1 7 *Fabric* F A B T H I R T Y T E A L B L U

Silvana Mangano: Absolute beauty. A sophisticated and profound actress. The Silvana chair is a multitasking seat designed for domestic use only. A low seat with well-defined features, comfortable and pivoting, with armrests and fully upholstered.

Other finishings: 51.bronze finish, 54.polished black nickel finish.

Silvana Mangano, bellezza assoluta, interprete raffinata e profonda. La poltroncina Silvana è una seduta poliedrica, adatta per il solo uso domestico. Una seduta bassa dai tratti definiti, comoda, girevole, con braccioli e interamente rivestita in tessuto.

Altre finiture: 51.finitura bronzo, 54.finitura nickel nero lucido.

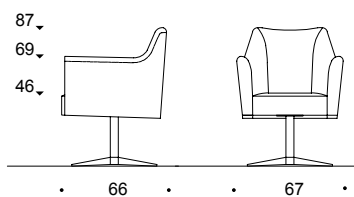



SILVANA LOUNGE



Design M A R C O P I V A

Cod. A 1 2 1 4 0 *Fabric* T R I C O T A G E C I T R O N

Silvana Mangano: Absolute beauty. A sophisticated and profound actress. The Silvana chair is a multitasking seat designed for domestic use only. A low seat with well-defined features, comfortable and pivoting, with armrests and fully upholstered.

Silvana Lounge was also designed as accessory and support seating for the sofas in the Cinecittà collection.

Other finishings: 51.bronze finish, 54.polished black nickel finish.

Silvana Mangano, bellezza assoluta, interprete raffinata e profonda. La poltroncina Silvana è una seduta poliedrica, adatta per il solo uso domestico. Una seduta bassa dai tratti definiti, comoda, girevole, con braccioli e interamente rivestita in tessuto.

Silvana Lounge è pensata anche come seduta di completamento e supporto ai divani della collezione Cinecittà.

Altre finiture: 51.finitura bronzo, 54.finitura nickel nero lucido.

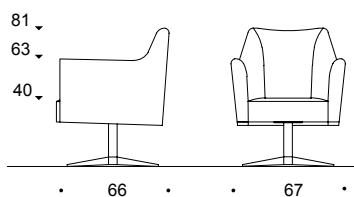



SOPHIA



Cod. A 1 2 0 9 9 *Design* M A R C O P I V A
Fabric S I L E N T M O V I E A R G E N T O

Sophia Pouf is distinctive in its soft, gentle shape. A "graphic mark" is engraved on the fabric as its feature, giving it a sense of uniqueness.

Other finishings: 51.bronze finish, 54.polished black nickel finish.

Il pouf Sophia si distingue per le sue forme morbide e delicate. Un "segno grafico" incide il tessuto, conferendogli un senso di unicità.

Altre finiture: 51.finitura bronzo, 54.finitura nickel nero lucido.

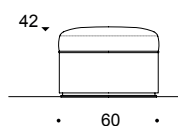

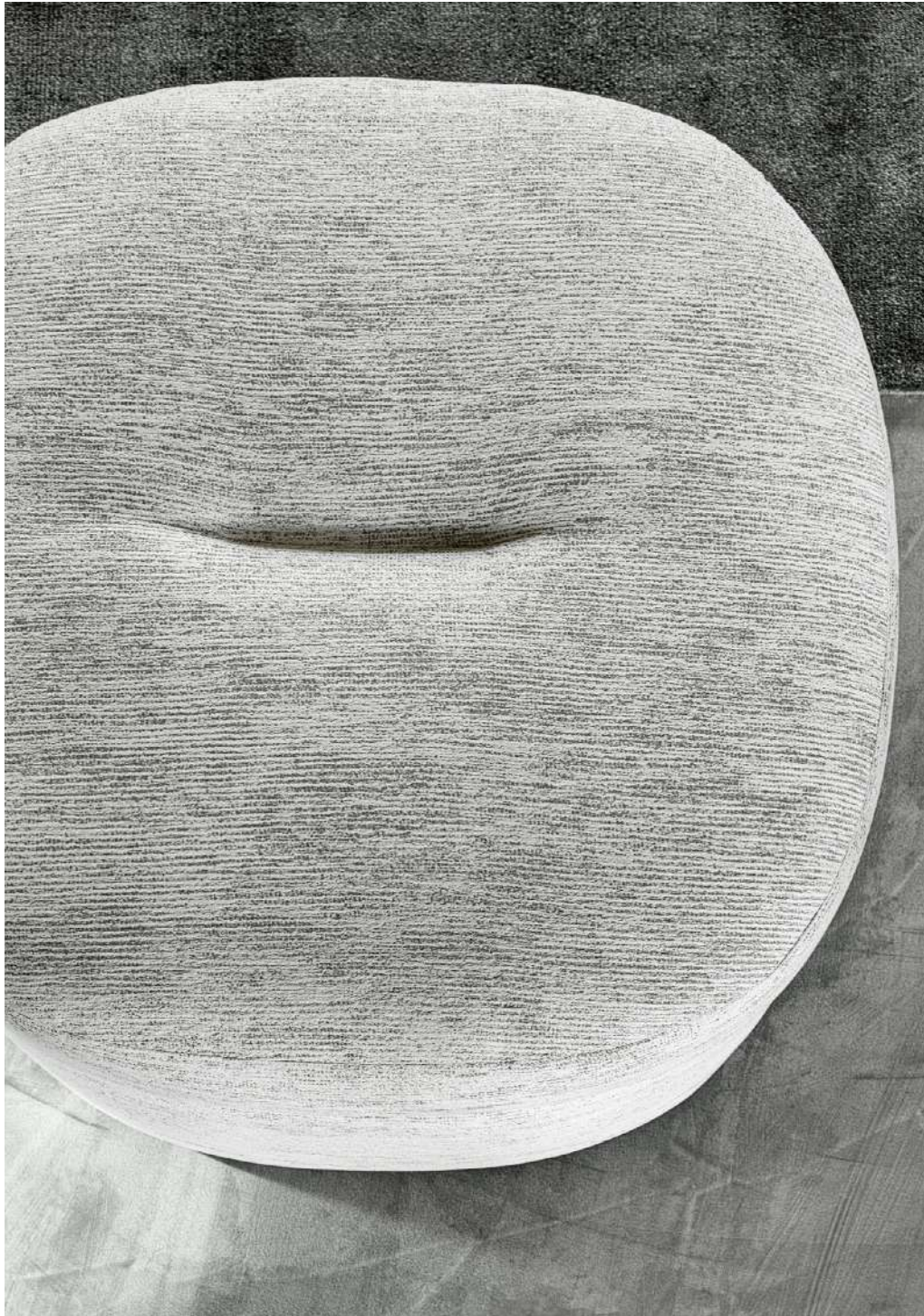

Design MARCO PIVA
Cod. A 1 2 0 9 9 *Fabric* MARCELLO PIETRA

SQUERARÒL



Design LUCA SCACCHETTI

Cod. A 1 2 0 4 7 *Fabric* TOILE DE VENISE ACQUA

Squeraròl is a straight bench with a slight curve in the beech frame, reminiscent of the soft lines of Venice bridges. Besides its function, this piece of furniture can also become a decorative element thanks to the wide range of Rubelli fabrics.

Finishing: 00.black lacquer.

Squeraròl è una panca lineare dalle leggere curvature nell'intelaiatura in faggio che ricordano le morbide linee dei ponti veneziani. Grazie all'ampia gamma di tessuti Rubelli, può facilmente diventare elemento di grande decorazione oltre che funzionale.

Finitura: 00.laccato nero.

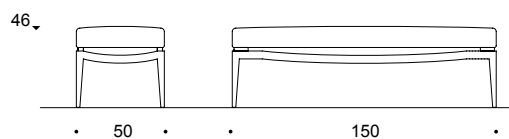



Design LUCA SCACCHETTI
Cod. A 1 2 0 4 7 *Fabric* VASARELY BEIGE

STEFANIA CLUB CHAIR



Design M A R C O P I V A

Cod. A 1 2 1 2 0

Fabric F A B T H I R T Y B O R D E A U X

Stefania Sandrelli. An understated, radiant and unique beauty. A chair designed for different spaces and situations, for relaxing, chatting, meditating, in the living area or the study, it can also be taken out onto the veranda or panoramic terraces. Stefania features lightweight tubular metal which surrounds and supports the seat with balance, giving it a suspended look. Comfort is ensured through the continuity between seat and back.

Other finishings: 51.bronze finish, 54.polished black nickel finish.

Stefania Sandrelli. Bellezza essenziale, solare, unica. Poltrona pensata per diverse situazioni e ambienti, per il relax, la conversazione, la meditazione: in salotto o nello studio, può essere portata anche in veranda e su terrazze panoramiche. Stefania è caratterizzata da un tubolare metallico leggero che circonda e sostiene armoniosamente la seduta facendola sembrare sospesa. Il comfort è garantito dalla continuità tra seduta e schienale.

Altre finiture: 51.finitura bronzo, 54.finitura nickel nero lucido.

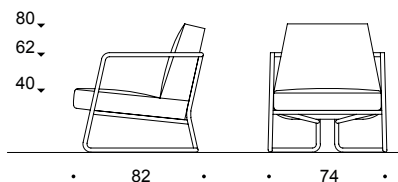



TELA



Design M A T T E O N U N Z I A T I
Cod. A 1 2 1 2 1 *Fabric* C R O C H E T

Tela is an armchair in which form and the materials used (wood and fabric here) interact closely and inextricably together to strengthen and enhance each other.

High manufacturing skill is offset by best use of the fabric. The structure of the seat is in hardwood. Tela is available in two wood types – natural walnut which enhances its elegance and radiance, or mocha stained ash which underscores its sinuous appearance.

Other finishings: Version dark - 38.moka stain ashwood, 102.brown leather, Version light - 82.natural walnut, 103.tortora leather.

Tela è una poltrona in cui forma e materiali impiegati (nello specifico legno e tessuto), in uno stretto e imprescindibile dialogo fra loro si rafforzano e si esaltano reciprocamente. Ad una grande sapienza costruttiva fa da contrappunto la massima valorizzazione del tessuto.

La struttura della seduta è realizzata in legno massello. Tela viene proposta in due essenze: noce naturale, che ne esalta eleganza e luminosità, oppure frassino tinto moka che ne mette in rilievo la sinuosità.

Altre finiture: Versione dark - 38.frassino tinto moka, 102.pelle marrone, Versione light - 82.noce naturale, 103.pelle tortora.

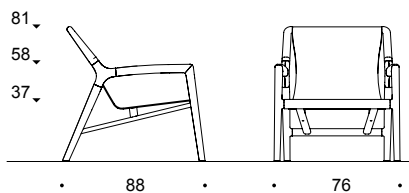



Design MATTEO NUNZIATI
Cod. A 1 2 1 2 1 *Fabric* CROCHET AVORIO



THE CAPITONNÉ REFERENCE THAT DISTINGUISHES THE *Triennale* RANGE IS SEEN IN THE TONAL COVER SEAMS THAT BECOME A DISTINCTIVE FEATURE. A NOSTALGIA RANGE THAT TAKES US BACK TO THE 1950S WITH CONTEMPORARY STYLE.

La citazione del capitonné, che distingue la serie *Triennale*, è presente attraverso le cuciture sul rivestimento, realizzate tono su tono, che diventano motivo distintivo. Una serie vagamente nostalgica che rimanda agli anni cinquanta, in stile contemporaneo.



Triennale Sofa 3 and Triennale Lounge
Chairs (Underground, royal blue), Greta
Trio, Rossellini Coffee Table Square with
Damantio® bronze top



TRIENNALE SOFA 2



Design S T U D I O R U B E L L I
Cod. A 1 2 1 0 5 *Fabric* O M B R A C O R A L L O

Triennale Sofa 2 is inspired by the 1950s Italian design and redesigned with contemporary style codes. Elegant and comfortable, with its strong personality, it becomes a key feature in formal living areas and areas for relaxation.

Other finishings: 51.bronze finish, 54.polished black nickel finish, 55.satin nickel, 56.satin brass finish.

Triennale Sofa 2 si ispira al design italiano degli anni '50, ma rivisto con codici contemporanei. Elegante e confortevole, con la sua spiccata personalità diviene protagonista in living formali e zone relax.

Altre finiture: 51.finitura bronzo, 54.finitura nickel nero lucido, 55.finitura nickel satinato, 56.finitura ottone satinato.

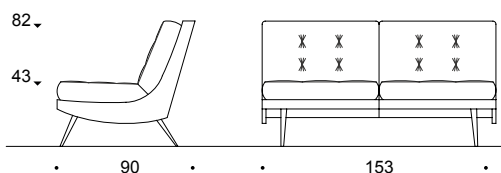

TRIENNALE SOFA 3



Design STUDIO RUBELLI

Cod. A 1 2 1 0 6

Fabric UNDERGROUND ROYAL BLU

Triennale Sofa 3 is inspired by the 1950s Italian design and redesigned with contemporary style codes. Elegant and comfortable, with its strong personality, it becomes a key feature in formal living areas and areas for relaxation.

Other finishings: 51.bronze finish, 54.polished black nickel finish, 55.satin nickel, 56.satin brass finish.

Triennale Sofa 3 si ispira al design italiano degli anni '50, ma rivisto con codici contemporanei. Elegante e confortevole, con la sua spiccata personalità diviene protagonista in living formali e zone relax.

Altre finiture: 51.finitura bronzo, 54.finitura nickel nero lucido, 55.finitura nickel satinato, 56.finitura ottone satinato.

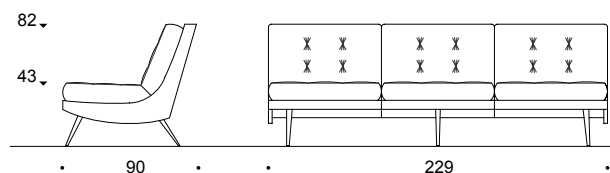

TRIENNALE LOUNGE



Design STUDIO RUBELLI

Cod. A 1 2 1 0 4

Fabric UNDERGROUND ROYAL BLU

Triennale Lounge Chair can double up and triple up to become a sofa. It features a “floating” structure on which large soft cushions rest. Elegant and comfortable, with its strong personality, it becomes a key feature in formal living areas and areas for relaxation.

Other finishings: 51.bronze finish, 54.polished black nickel finish, 55.satin nickel, 56.satin brass finish.

La poltrona Triennale può raddoppiarsi e triplicarsi per diventare un divano. È caratterizzata da una struttura “galleggiante” sulla quale poggiano grandi e morbidi cuscini trapuntati. Elegante e confortevole, con la sua spiccata personalità diviene protagonista in living formali e zone relax.

Altre finiture: 51.finitura bronzo, 54.finitura nickel nero lucido, 55.finitura nickel satinato, 56.finitura ottone satinato.

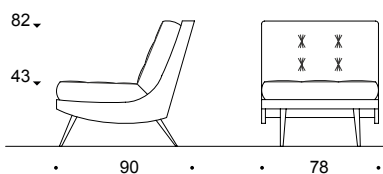



TWILL



Design MATTEO NUNZIATI

Cod. A 1 2 1 2 2 *Fabric* NUANCE DU SABLE GRIS SAUGE

Cod. A 1 2 1 2 7 *Fabric* NUANCE DU SABLE POUFRE

Series of poufs with built-in support surface available in Natural Walnut or Moka Stained Ash. The piece thus becomes multifunctional – informal yet stylish seating and at the same time a table surface.

Other finishings: wooden box 38.moka stain ashwood, 82.natural walnut.

Una serie di pouf con un piano di appoggio integrato che può essere realizzato in legno noce naturale o frassino tinto moka. In questo modo questo pezzo diviene multifunzionale: seduta informale, ma elegante e allo stesso tempo tavolo d'appoggio.

Altre finiture: box in legno 38.frassino tinto moka, 82.noce naturale.

Cod. A12122

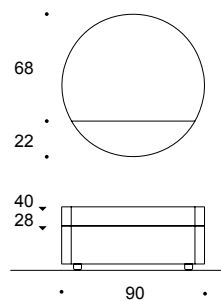

Cod. A12127

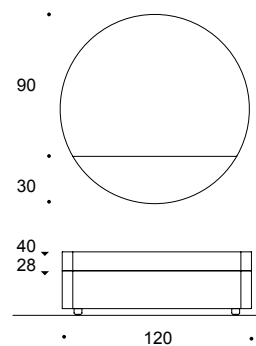





A BLEND OF INNOVATIVE RESEARCH
AND SOPHISTICATED CRAFT SKILLS,
THE *Velour* RANGE STANDS OUT
THROUGH THE CURVED SHAPE
EXPRESSING COMFORT AND RELAXATION.
THE ABSOLUTE ELEGANCE EVEN
WHEN SEEN FROM THE BACK, THANKS
TO THE LEATHER UPHOLSTERED
BACKREST THAT REVEALS ITS FLEXIBLE
STRUCTURE, ENSURES ITS LEADING
ROLE ALSO AT THE CENTRE OF A ROOM.

Sintesi di ricerca innovativa e di sofisticata manualità artigianale, la serie *Velour* si distingue per la forma curvilinea che esprime comfort e relax. L'estrema eleganza anche di spalle, grazie al rivestimento in cuoio dello schienale che dichiara la sua struttura flessibile, le assicura un ruolo di grande interprete anche al centro stanza.



Velour sofa with back in leather Lago
Testà di Moro, seat in Nuance du sable
fabric as Velour armchair and Twill pouf.



VELOUR SOFA



Design M A T T E O N U N Z I A T I
Fabric V E L V E T Y G R I G I O

Velour is a seating range featuring generous, soft and inviting shapes. The curved shell which shapes the back and arms is in bent wood and can be upholstered in leather or fabric. The fabric details, such as the piping which enhances the curved outline of the seats or the double and single seams framing the shapes, underline the strongly crafted and sophisticated workmanship involved in the details.

Other finishings: feet 01.stained in dark wenge.

Velour è un sistema di sedute caratterizzata da forme generose, morbide ed accoglienti. La scocca curva, che definisce lo schienale e i braccioli, è realizzata in legno curvato e può essere rivestita in pelle o tessuto. I dettagli tessili - come il piping che esalta il profilo curvo delle sedute oppure le cuciture doppie e singole che incorniciano le forme - sottolineano la fattura altamente artigianale e ricercata dei dettagli.

Altre finiture: piedi: 01.tinto wengè scuro.

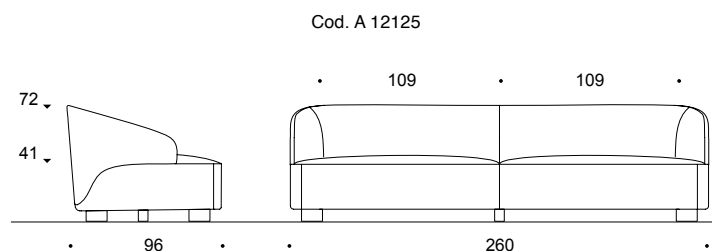
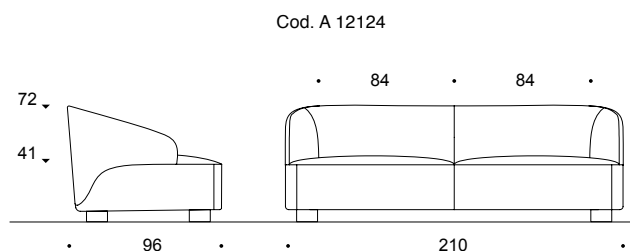

VELOUR CHAISE LONGUE



Design MATTEO NUNZIATI

Cod. A 1 2 1 2 6 *Fabric* VELVETY MADREPERLA *Leather* LAGO ARGILLA

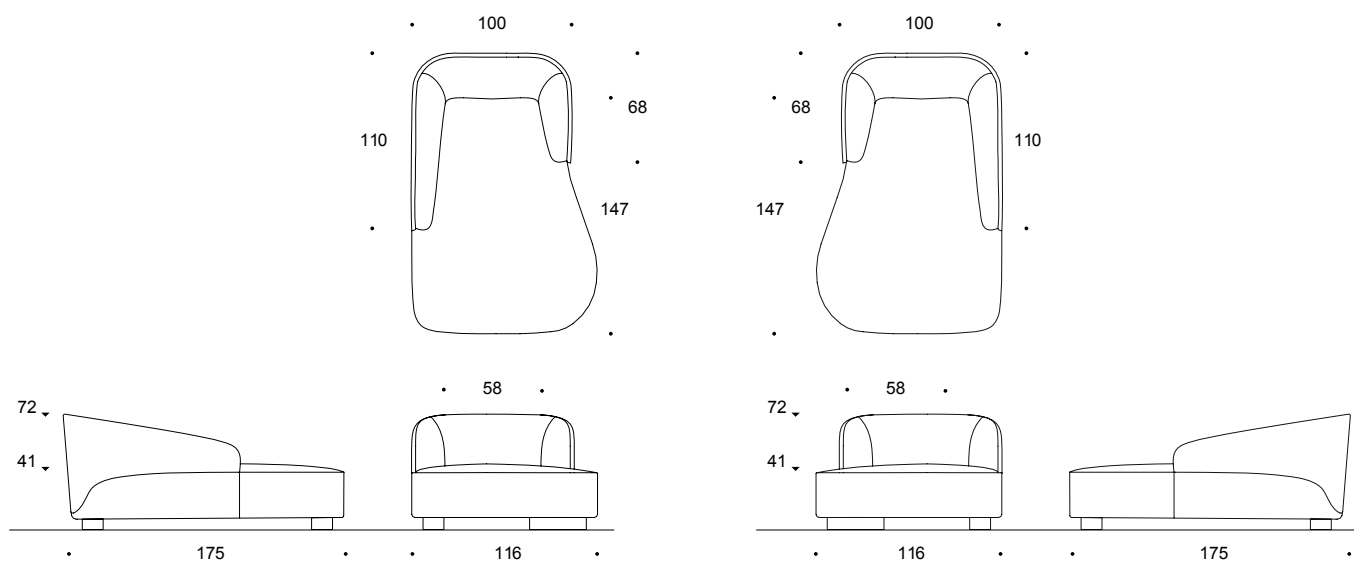

VELOUR ARMCHAIR



Design MATTEO NUNZIATI

Cod. A 1 2 1 2 3 *Fabric* NUANCE DU SABLE POU DRE

Leather LAGO TESTA DI MORO

Velour is a seating range featuring generous, soft and inviting shapes. The curved shell which shapes the back and arms is in bent wood and can be upholstered in leather or fabric. The fabric details, such as the piping which enhances the curved outline of the seats or the double and single seams framing the shapes, underline the strongly crafted and sophisticated workmanship involved in the details.

Other finishings: feet 01. stained in dark wenge.

Velour è un sistema di sedute caratterizzata da forme generose, morbide ed accoglienti. La scocca curva, che definisce lo schienale e i braccioli, è realizzata in legno curvato e può essere rivestita in pelle o tessuto. I dettagli tessili - come il piping che esalta il profilo curvo delle sedute oppure le cuciture doppie e singole che incorniciano le forme - sottolineano la fattura altamente artigianale e ricercata dei dettagli.

Altre finiture: piedi: 01. tinto wengè scuro.

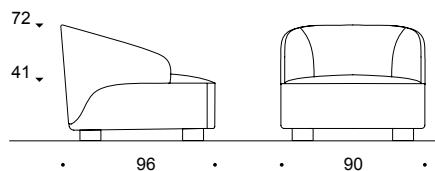



ANITA



Design M A R C O P I V A

Cod. A 1 2 0 9 5 *Fabric* D I S O G R A F I T E

Anita is a homage to Anita Ekberg, the Swedish sex-symbol of La Dolce Vita film. Anita is cushiony and impactful. The chair combines sleek shapes, dictated by the movements of the fabric, with a high technical value which makes it suitable for several uses. The graphic line of the edging is seen as a distinctive element. The tall back becomes an armrest following the movement of the seat. The hardness of the wood meets the softness of the fabric. The Anita Armchair matches with the B.B. Side Chair.

Finishing: 38.moka stain ashwood.

Anita è un omaggio a Anita Ekberg, la sex-symbol svedese de La Dolce Vita. La sedia Anita è avvolgente e di impatto. Unisce alla sinuosità delle forme, dettate dai movimenti del tessuto, un'alta tecnica, che la rende adatta a molteplici usi. È caratterizzata da uno schienale alto che diventa bracciolo seguendo il movimento della seduta. La durezza del legno incontra la morbidezza del tessuto. Anita si accompagna alla sedia B.B., versione senza braccioli.

Finitura: 38.frassino tinto moka.

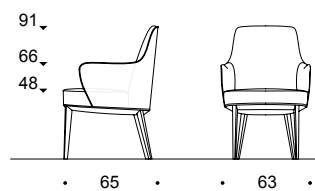

without arm: B.B. - Cod.A12094 pag.142

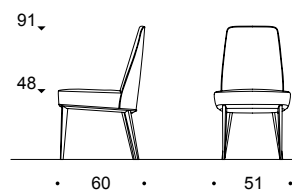



Design MARCO PIVA
Cod. A 1 2 0 9 5 *Fabric* FABTHIRTY ROSA

ASCARI



Design S T U D I O R U B E L L I
Cod. A 1 2 0 9 7 Fabric K A R L S A L E P E P E

Ascari is a homage to Alberto Ascari, the Italian racing driver famous for his style of driving. Ascari, like Nuvolari, is a dining chair which echoes the successful elements of two key armchairs in the Rubelli Casa collection: the sinuous edge of the back of the Clintòn and the “opening” in the back of Barbacàn. Ascari is the version without armrests. The curved back is an invitation to relax. To be considered from every angle and perspective in order to appreciate its elegant silhouette and the many details of high tailoring.

Finishing: 01.stained in dark wenge.

Ascari è un omaggio a Alberto Ascari, il famoso pilota italiano dallo stile di guida preciso e rispettoso. Ascari, come Nuvolari, è una sedia da pranzo che riprende elementi che hanno decretato il successo di due poltrone di punta della collezione Rubelli Casa: il “bordo” sinuoso dello schienale della Clintòn e “l’apertura” nello schienale della Barbacàn. Ascari è la versione senza braccioli. Lo schienale curvilineo invita al relax. Da guardare da ogni angolazione e prospettiva per apprezzarne l’eleganza della silhouette e i molteplici dettagli di altissima sartorialità.

Finitura: 01.tinto wengè scuro.

with arm: NUVOLARI - Cod.A12096 pag.144

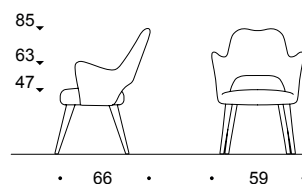
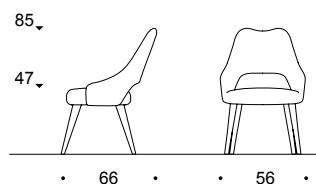



Design STUDIO RUBELLI
Cod. A 1 2 0 9 7 *Fabric* OLIMPIA LAGUNA

B.B.



Design M A R C O P I V A
Cod. A 1 2 0 9 4 *Fabric* N I R V A N A G R I G I O

B.B. stands for Brigitte Bardot, a simple and sophisticated film star. The B.B. chair has important technical value, gained from the use of two separate and opposing material volumes. An elegant wooden “frame” - the same used for the legs - works as a support for the seat in fabric which displays details of very high sartorial quality. Tall, but not invasive back, without armrests. Simple and straight shape. The B.B. Side Chair matches with Anita Arm Chair.

Finishing: 38.moka stain ashwood.

B.B. sta per Brigitte Bardot, stella del cinema, sensuale e raffinata. La sedia B.B. ha un notevole valore tecnico, dato dall'utilizzo di due volumi materici distinti e antitetici. Un'elegante “cornice” in legno - lo stesso delle gambe - funge da appoggio alla seduta in tessuto che evidenzia dettagli di altissima sartorialità. Seduta con schienale alto, ma non invasivo, senza braccioli. Forma semplice e lineare. Si accompagna alla sedia Anita, versione con braccioli.

Finitura: 38.frassino tinto moka.

with arm: ANITA - Cod.A12095 pag.138

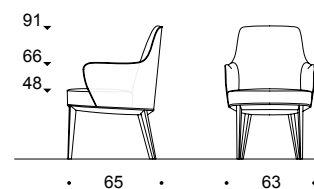
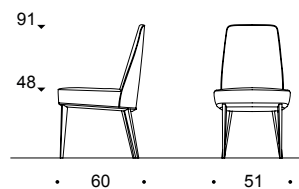



NUVOLARI



Design STUDIO RUBELLI
Cod. A 1 2 0 9 6 Fabric SPRITZ CORALLO

Nuvolari refers to Tazio Nuvolari, the famous champion racing driver who won even without a steering wheel. Nuvolari, like Ascari, is a dining chair which echoes the successful elements of two key armchairs in the Rubelli Casa collection: the sinuous edge of the back of the Clintòn and the “opening” in the back of Barbacàn. Nuvolari is the version with armrests. The curved back is an invitation to relax. To be considered from every angle and perspective in order to appreciate its elegant silhouette and the many details of high tailoring.

Finishing: 01.stained in dark wenge.

Nuvolari si riferisce a Tazio Nuvolari, il famoso campione che vinceva anche senza volante. Nuvolari, come Ascari, è una sedia da pranzo che riprende elementi che hanno decretato il successo di due poltrone di punta della collezione Rubelli Casa: il “bordo” sinuoso dello schienale della Clintòn e “l’apertura” nello schienale della Barbacàn. Nuvolari è la versione con braccioli. Lo schienale curvilineo invita al relax. Da guardare da ogni angolazione e prospettiva per apprezzarne l’eleganza della silhouette e i molteplici dettagli di altissima sartorialità.

Finitura: 01.tinto wengè scuro.

without arm: ASCARI - Cod.A12097 pag.140

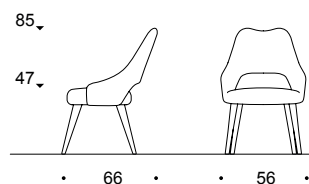
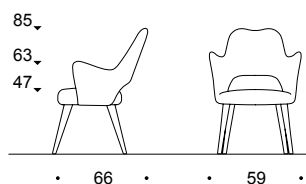



VIRNA



Design M A R C O P I V A
Cod. A 1 2 1 1 8 *Fabric* F A B T H I R T Y R O S S O

Virna Lisi. The utmost in sophisticated chic. Sleek and enveloping, yet at the same time strongly defined, the Virna chairs feature soft and welcoming seats and backs, covered in colour block fabric. The edges of the back are outlined by welt, their distinctive feature. The stained wood base is designed as a continuation of the upholstered shapes for a lightweight and well-proportioned end result.

Finishing: 38.moka stain ashwood.

Virna Lisi. L'eleganza più sofisticata. Avvolgenti e sinuose, ma al contempo decise, le sedie Virna sono caratterizzate da sedute e schienali morbidi ed accoglienti, rivestiti in tessuto in tinta unita. I profili dello schienale sono "disegnati" da un cordino (piping) che ne costituisce il tratto distintivo. La base in legno tinto si esprime in continuità con le forme imbottite per un risultato leggero ed armonioso.

Finitura: 38.frassino tinto moka.

without arm: B.B - Cod.A12094 pag.142

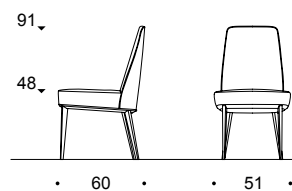
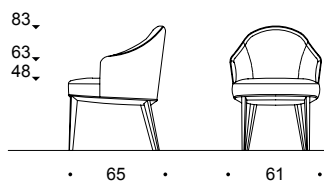



Design MARCO PIVA
Cod. A 1 2 1 1 8 *Fabric* VELVETFORTY INDACO

PIANO RECTANGULAR



Design NAVA + AROSIO
Cod. A 1 6 0 2 0

The Piano collection has expanded and the new version of the dining table with rectangular top is born. The central leg of the round table version is divided into two parts to support the generous rectangular top with bevelled corners. The sculptural and simultaneously lightweight features of the table remain unchanged and, thanks to a special attachment plate, it allows the two legs to be turned in different positions (perpendicular or slanting at 45° in relation to the top), bringing a sense of movement to the table.

Other finishings: base: 82.natural walnut, 101. chocolate walnut; metal base: 100.matt black nichel finish; top: 82.natural walnut, 101.chocolate walnut.

La Piano collection si amplia: nasce la nuova versione del dining table con top rettangolare. La gamba centrale della versione del tavolo rotondo si scinde in due parti per sostenere il generoso top rettangolare con angoli smussati. Rimangono immutate le caratteristiche scultoree e allo stesso tempo di leggerezza del tavolo che, grazie ad una particolare piastra di fissaggio, permette di orientare le due gambe in differenti posizioni (perpendicolari o inclinate a 45° rispetto al top) conferendo dinamismo al tavolo.

Altre finiture: base: 82.noce naturale, 101. noce cioccolato; base metallo: 100.finitura nichel nero opaco; top: 82.noce naturale, 101.noce cioccolato.

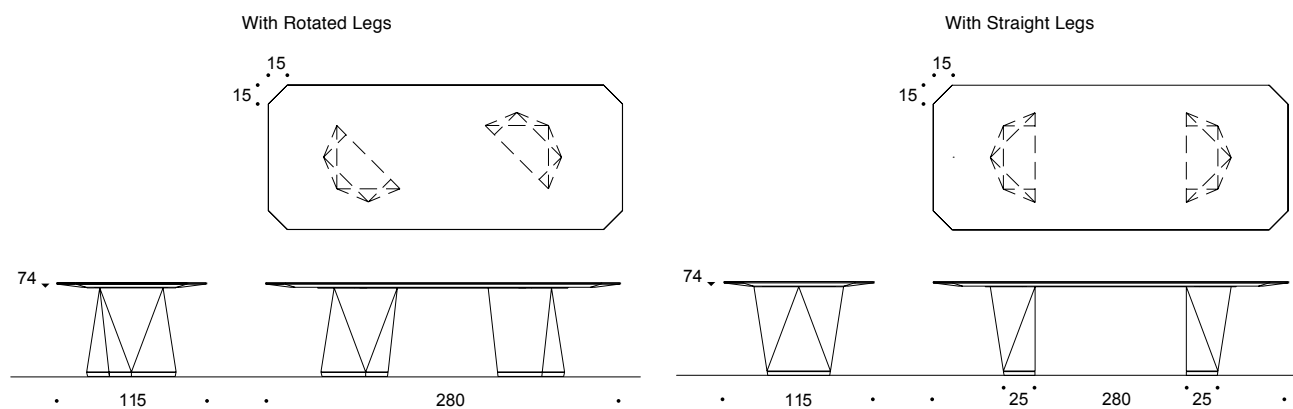

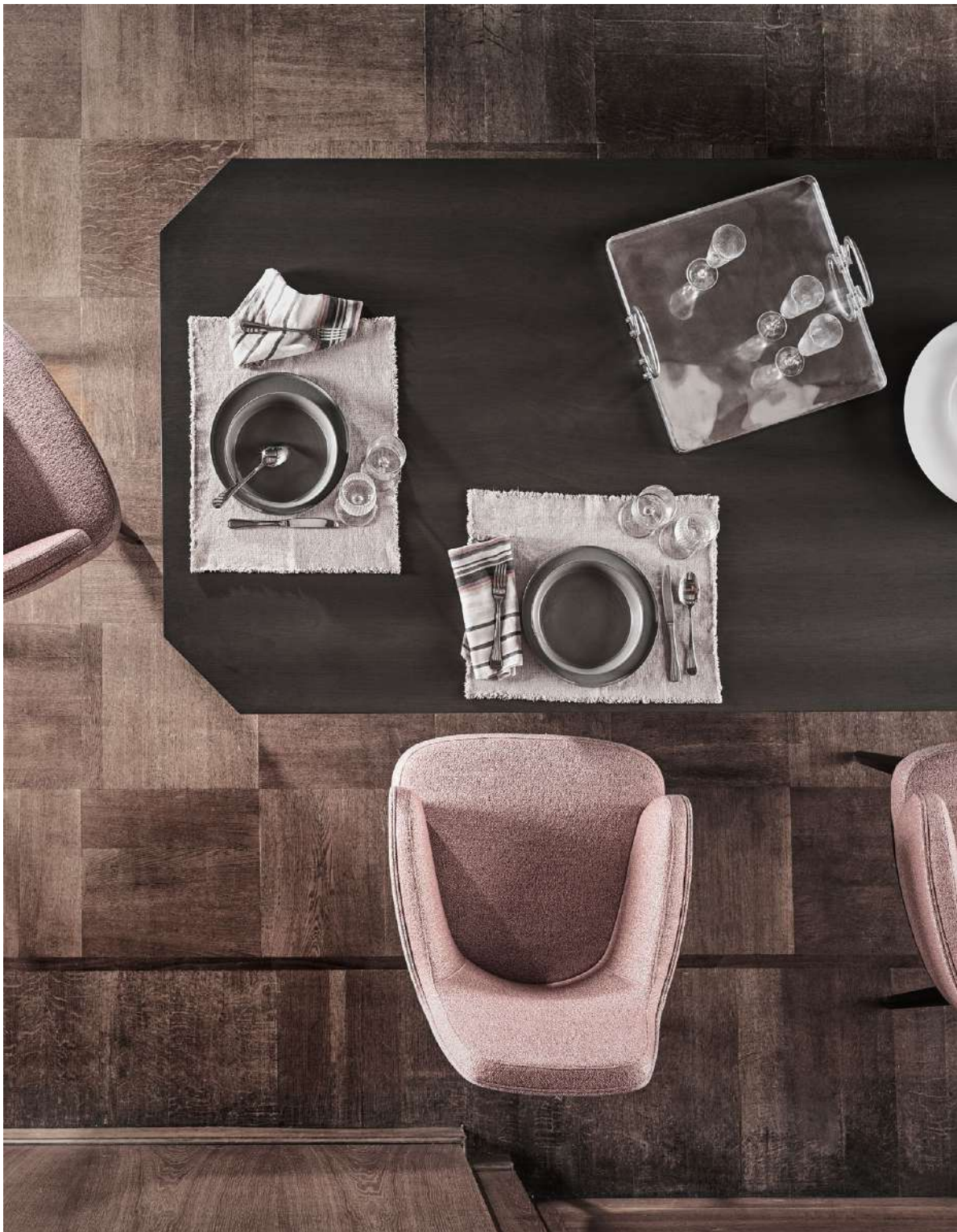



Piano Rectangular in Chocolate walnut
and Anita arm chair in moka stain
ashwood, seat in Fabthirty rosa fabric.



PIANO ROUND



Design NAVA + AROSIO
Cod. A 1 6 0 1 1 (ø 1 6 0) *Cod.* A 1 6 0 1 7 (ø 1 8 0)

A sculptural yet lightweight table in which the central leg, produced from a flat board modelled with the folding technique and available in two different types of walnut, is an unbroken sequence of different facets. The top, in the two versions in wood, is divided in four sections characterized by the herringbone arrangement of the striped veining of the walnut. The 180 cm diameter table is also available with the top in Calacatta marble and can seat up to 10 people.

Other finishings: base: 82.natural walnut, 101. chocolate walnut; metal base: 100. matt black nichel finish; top: 82.natural walnut, 101.chocolate walnut, 73.Calacatta Vagli marble.

Un tavolo scultoreo ma leggero, in cui la gamba centrale, ottenuta da una lastra piana modellata con la tecnica del folding e proposta in due differenti tipi di noce, è un susseguirsi di sfaccettature diverse. Il top, nelle due versioni in legno, è suddiviso in 4 sezioni caratterizzate dalle venature rigate del noce disposte a spina di pesce. Disponibile anche nella versione in marmo Calacatta, il top con diametro 180 cm. può ospitare fino a 10 persone.

Altre finiture: base: 82.noce naturale, 101. noce cioccolato; base metallo: 100. finitura nichel nero opaco; top: 82.noce naturale, 101 noce cioccolato, 73.marmo Calacatta Vagli.

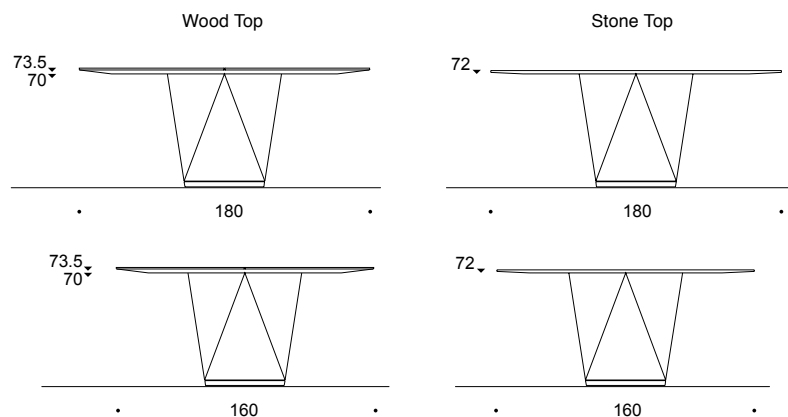



RODOLFO OVAL



Design M A R C O P I V A
Cod. A 1 6 0 0 7

Rodolfo stands for Rodolfo Valentino, the famous actor, known as the "Latin lover". Like twisting prisms which rise upwards, the metal legs of the table feature a change in geometry which streamlines them and supports the monumental nature of the top, creating an elegant textural and colour contrast. Strong character. Solid yet with a lightweight appearance. The top can be round or oval, and available in different finishes.

Other finishings: base: 51.bronze finish, 54.polished black nickel finish; top: 37.eucalyptus pomele natural, 101.chocolate walnut.

Rodolfo è un rimando a Rodolfo Valentino, il famoso attore, noto anche come il "Latin lover". Come prismi in torsione che si elevano verso l'alto, le gambe in metallo del tavolo sono caratterizzate da un cambio di geometria che le slancia a sorreggere la monumentalità del piano, creando un elegante contrasto materico e cromatico. Carattere deciso. Solido, ma alla vista leggero. Il piano rotondo o ovale è disponibile in diverse finiture.

Altre finiture: base: 51.finitura bronzo, 54.finitura nickel nero lucido; top: 37. legno ecaulipto pomele naturale, 101.noce cioccolato.

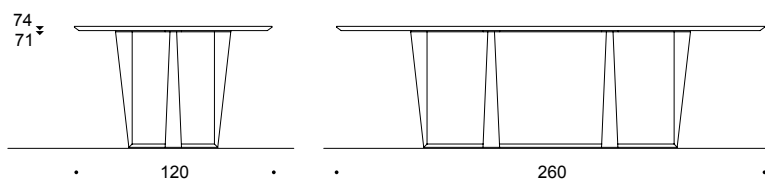



RODOLFO ROUND



Design M A R C O P I V A
Cod. A 1 6 0 0 6

Rodolfo stands for Rodolfo Valentino, the famous actor, known as the "Latin lover". Like twisting prisms which rise upwards, the metal legs of the table feature a change in geometry which streamlines them and supports the monumental nature of the top, creating an elegant textural and colour contrast. Strong character. Solid yet with a lightweight appearance. The top can be round or oval, and available in different finishes.

Other finishings: base: 51.bronze finish, 54.polished black nickel finish; top: 37.eucalyptus pomele natural, 101.chocolate walnut.

Rodolfo è un rimando a Rodolfo Valentino, il famoso attore, noto anche come il "Latin lover". Come prismi in torsione che si elevano verso l'alto, le gambe in metallo del tavolo sono caratterizzate da un cambio di geometria che le slancia a sorreggere la monumentalità del piano, creando un elegante contrasto materico e cromatico. Carattere deciso. Solido, ma alla vista leggero. Il piano rotondo o ovale è disponibile in diverse finiture.

Altre finiture: base: 51.finitura bronzo, 54.finitura nickel nero lucido; top: 37. legno ecaulipto pomele naturale, 101.noce cioccolato.

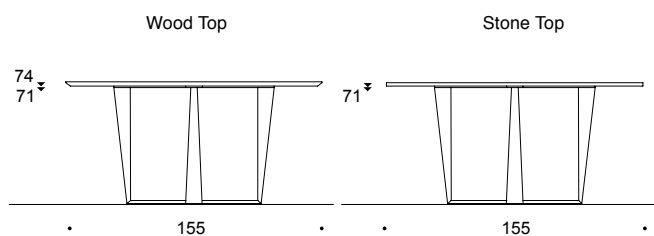



SCHOLA GRANDA CARD



Design L U C A S C A C C H E T T I
Cod. A 1 2 0 7 5

Schola Granda Card Table, like the other tables in the Schola Granda collection, stands out through the original decorative feature – almost a capital – in satin finish brass which joins the legs to the top. Frame and round top are in black lacquer finish wood. A creation by Luca Scacchetti with Art Deco inspiration.

Finishing: structure and top: 00.black lacquer; metal elements: 56.satin brass finish.

Schola Granda Card Table, come gli altri tavoli della collezione Schola Granda, si distingue per l'originale elemento decorativo - quasi un capitello in metallo finitura in ottone satinato - che unisce le gambe al piano. La struttura e il piano circolare sono in legno laccato nero. Di ispirazione Art Déco, è una creazione di Luca Scacchetti.

Finitura: struttura e top: 00.laccato nero; elementi metallo: 56.finitura ottone satinato.

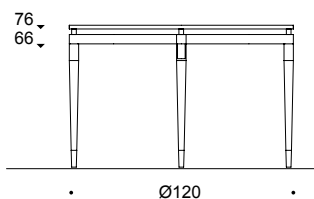

SCHOLA GRANDA FLOWER



Design L U C A S C A C C H E T T I
Cod. A 1 2 0 3 5

Featuring a graceful floral shape on its top, the Flower Top variant of the Schola Granda collection is a well-proportioned table inspired by Art Deco, in which the shaped wood frame is embellished with capitals in satin brass finish which join the base to the top.

Finishing: structure and top: 00.black lacquer; metal elements: 56.satin brass finish.

Caratterizzato dall'aggraziata forma floreale del piano, la variante Flower Top della collezione Schola Granda è un tavolo armonioso che si ispira all'Art Déco, in cui la struttura sagomata di legno è impreziosita da capitelli di metallo con finitura in ottone satinato che uniscono la base al piano.

Finitura: struttura e top: 00.laccato nero; elementi metallo: 56.finitura ottone satinato.

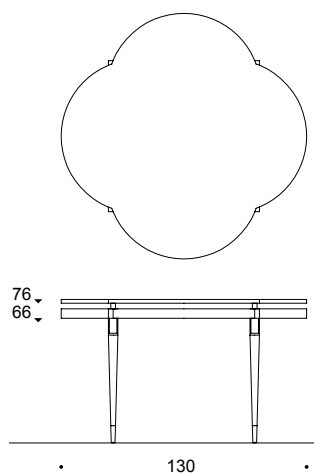

SCHOLA GRANDA FLOWER



Design LUCA SCACCHETTI
Cod. A 1 2 0 3 5



AGO



Design M A T T E O N U N Z I A T I
Cod. A 1 6 0 1 9

Ago is a coffee table in mocha stained ash hardwood, with slightly rounded corners to showcase the artisanal quality of work on the details. The top can be made in marble or leather. A leather magazine pocket can also be ordered for the rear part, an additional detail that references high-end leatherworking.

Other finishings: body 38.moka stain ashwood, top 73.Calacatta Vagli marble, 74.Emperador dark marble, 102.brown leather, folder 102.brown leather.

Ago è un tavolino in legno massello in frassino tinto moka. Gli angoli sono leggermente arrotondati per evidenziare la qualità artigianale della lavorazione dei dettagli. Il piano può essere realizzato in marmo o cuoio. Nella parte posteriore può essere richiesta una tasca portariviste in cuoio. Questo ulteriore dettaglio rimanda alle lavorazioni artigianali di alta conceria.

Altre finiture: struttura 38.frassino tinto moka, top 73.marmo Calacatta Vagli, 74.marmo Emperador dark, 102.pelle marrone, tasca 102.pelle marrone.

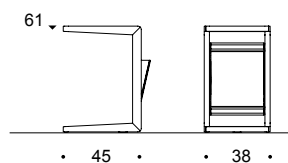



ASOLA COFFEE TABLE



Design M A T T E O N U N Z I A T I
Cod. A 1 6 0 2 2

Asola is a range of seating, low tables and poufs featuring a fabric-covered base supported by feet in mocha stained ash. The low tables, in line with the structure of the sofas, also have a base upholstered in fabric which rests on feet in ash. The top is available in different materials.

Other finishings: legs 38.moka stain ashwood, top 73.Calacatta Vagli marble, 74.Emperador dark marble, 90.bronze Damantio®, 92.silver Damantio®.

Asola è un sistema di sedute, tavoli bassi e pouf caratterizzati da una base sollevata da terra rivestita in tessuto e retta dai piedini in frassino tinto moka. I tavoli bassi, in linea con la struttura dei divani, presentano anch'essi una base rivestita di tessuto che poggia su piedini in frassino. Il top è disponibile in materiali diversi.

Altre finiture: piedi 38.frassino tinto moka, top 73.marmo Calacatta Vagli, 74.marmo Emperador dark, 90.Damantio® bronzo, 92.Damantio® argento.

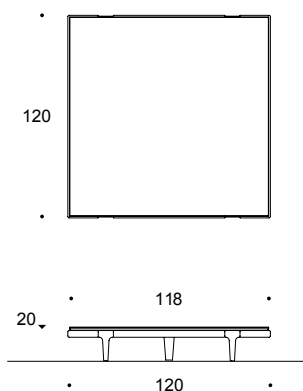



BAÙTA



Design L U C A S C A C C H E T T I

Cod. A 1 2 0 6 4 L A R G E *Cod.* A 1 2 0 6 5 M E D I U M *Cod.* A 1 2 0 6 6 T A L L

Elegant and minimalist, the Baùta tables are three coffee tables in different heights. Lightweight, almost suspended on the slim metal frame finished in bronze colour, and the base in natural walnut. The large table can have the top either in natural walnut or Fior di Pesco marble. The medium and the tall tables can have the top in natural walnut or in polished tortora lacquer.

Other finishings: structure: 51.bronze finish; top: 40.polished tortora colour lacquer, 71.fior di pesco carnico marble, 82.natural walnut.

Eleganti e minimalisti, i Baùta Tables sono tre coffee tables in diverse altezze. Leggeri, quasi sospesi sull'esile struttura metallica con finitura color bronzo e la base in noce naturale. Il tavolino grande può avere il top in noce naturale o in marmo Fior di Pesco. Il tavolino medio e quello basso possono avere il top in noce naturale o in laccato lucido color tortora.

Altre finiture: struttura: 51.finitura bronzo; top: 40.laccato lucido color tortora, 71.marmo fior di pesco carnico, 82.noce naturale.

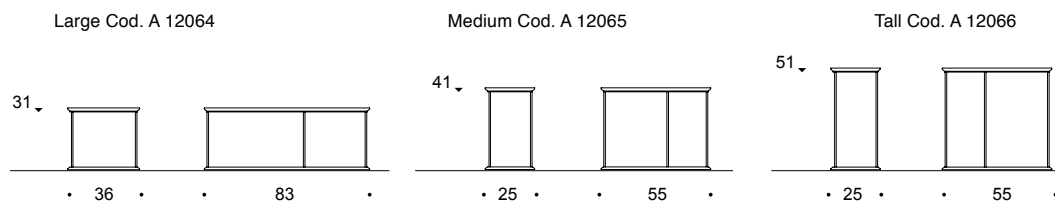



CALLE STELLA



Design L U C A S C A C C H E T T I
Cod. A 1 2 1 4 2

Bringing designs from the Fifties up to date, Luca Scacchetti has designed Calle Stella. The metal base is finished with bronze finish and wood features in Chocolate Walnut. The top finish is in extra-clear or bronzed tempered glass.

Other finishings: structure: 51.bronze finish, 101.chocolate walnut; top: 60.extra clear glass, 62.bronze glass.

Attualizzando forme anni '50, Luca Scacchetti ha disegnato Calle Stella, un tavolino decorativo essenziale, dall'architettura metallica con finitura bronzo ed elementi lignei in Noce Cioccolato. Il piano è in vetro temprato extra chiaro o bronzato.

Altre finiture: struttura: 51.finitura bronzo, 101. noce cioccolato; top: 60.vetro extra chiaro, 62.vetro bronzato.

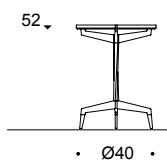



CONTRADA TRIO



Design L U C A S C A C C H E T T I

Cod. A 1 6 0 1 0 L A R G E *Cod.* A 1 6 0 0 9 M E D I U M *Cod.* A 1 6 0 0 8 S M A L L

Set of three occasional tables designed by Luca Scacchetti. Both the frame and the removable tray are made in ash with a moka stain finish. The tray has got an inset decoration in glass or in Damantio®, the exclusive material patented by Rubelli, available in 2 colours: bronze and silver.

Other finishings: structure: 38.moka stain ashwood; top: 60.extra clear glass, 90.bronze Damantio®, 92.silver Damantio®.

Set di tre tavolini creati da Luca Scacchetti. Sia la struttura che il vassoio asportabile sono in frassino tinto moka. Il vassoio ha un inserto decorativo in vetro o in Damantio®, esclusivo materiale brevettato da Rubelli, disponibile in 2 colori: bronzo e argento.

Altre finiture: struttura: 38.frassino tinto moka; top: 60.vetro extra chiaro, 90.Damantio® bronzo, 92.Damantio® argento.

Large Cod. A 16010

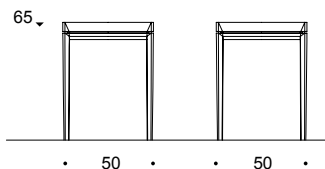

Medium Cod. A 16009

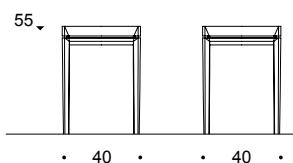

Small Cod. A 16008

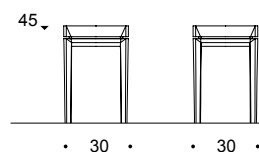



FELLINI OVAL



Design M A R C O P I V A
Cod. A 1 6 0 1 5

Federico Fellini. A genius. Brilliant and ironic. The Fellini coffee tables are an evolution of the Rossellini coffee tables. The same shapes feature slightly rounded forms, but simplified. While the top of the Rossellini coffee tables is in Damantio®, a decorative material patented by Rubelli in 2017 - a byword for technological innovation applied to creativity - the top of the Fellini coffee table is made of wood: either available in different Eucalyptus variants or in a walnut version. The new coffee tables have a single tube-shaped base with a rectangular section, instead of the double metallic “ribbon” as is seen in the Rossellini tables.

Other finishings: base structure: 51.bronze finish, 54.polished black nickel finish; top: 37.eucalyptus pomele natural, 82.natural walnut.

Federico Fellini. Geniale e ironico. I coffee tables Fellini rappresentano un’evoluzione dei coffee tables Rossellini, di cui riprendono – semplificandole - le forme e le linee leggermente stondate. A differenza dei Rossellini, che hanno il piano in Damantio® - materiale decorativo brevettato da Rubelli nel 2017, sinonimo di innovazione tecnologica applicata alla creatività - i Fellini vengono proposti con il piano in legno: Eucalipto pomelè naturale oppure noce naturale. Inoltre le basi dei nuovi tavolini vedono unirsi in un unico corpo, un tubo a sezione rettangolare, il doppio “nastro” metallico, già elemento distintivo dei Rossellini.

Altre finiture: base struttura: 51.finitura bronzo, 54.finitura nickel nero lucido; top: 37.legno ecaulipto pomele naturale, 82.noce naturale.

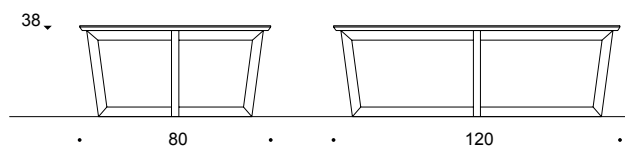



FELLINI SQUARE



Design M A R C O P I V A
Cod. A 1 6 0 1 6

Federico Fellini. A genius. Brilliant and ironic. The Fellini coffee tables are an evolution of the Rossellini coffee tables. The same shapes feature slightly rounded forms, but simplified. While the top of the Rossellini coffee tables is in Damantio®, a decorative material patented by Rubelli in 2017 - a byword for technological innovation applied to creativity - the top of the Fellini coffee table is made of wood: either available in different Eucalyptus variants or in a walnut version. The new coffee tables have a single tube-shaped base with a rectangular section, instead of the double metallic “ribbon” as is seen in the Rossellini tables.

Other finishings: base structure: 51.bronze finish, 54.polished black nickel finish; top: 37.eucalyptus pomele natural, 82.natural walnut.

Federico Fellini. Geniale e ironico. I coffee tables Fellini rappresentano un’evoluzione dei coffee tables Rossellini, di cui riprendono – semplificandole - le forme e le linee leggermente stondate. A differenza dei Rossellini, che hanno il piano in Damantio® - materiale decorativo brevettato da Rubelli nel 2017, sinonimo di innovazione tecnologica applicata alla creatività - i Fellini vengono proposti con il piano in legno: Eucalipto pomelè naturale oppure noce naturale. Inoltre le basi dei nuovi tavolini vedono unirsi in un unico corpo, un tubo a sezione rettangolare, il doppio “nastro” metallico, già elemento distintivo dei Rossellini.

Altre finiture: base struttura: 51.finitura bronzo, 54.finitura nickel nero lucido; top: 37.legno ecaulipto pomele naturale, 82.noce naturale.

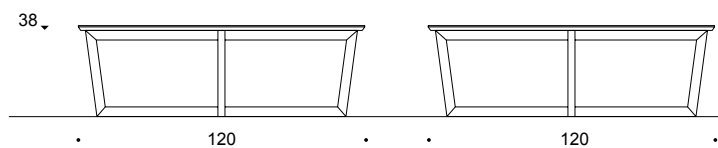

FELLINI TALL



Design M A R C O P I V A

Cod. A 1 6 0 1 4

Federico Fellini. A genius. Brilliant and ironic. The Fellini coffee tables are an evolution of the Rossellini coffee tables. The same shapes feature slightly rounded forms, but simplified. While the top of the Rossellini coffee tables is in Damantio®, a decorative material patented by Rubelli in 2017 - a byword for technological innovation applied to creativity - the top of the Fellini coffee table is made of wood: either available in different Eucalyptus variants or in a walnut version. The new coffee tables have a single tube-shaped base with a rectangular section, instead of the double metallic “ribbon” as is seen in the Rossellini tables.

Other finishings: base structure: 51.bronze finish, 54.polished black nickel finish; top: 37.eucalyptus pomele natural, 82.natural walnut.

Federico Fellini. Geniale e ironico. I coffee tables Fellini rappresentano un’evoluzione dei coffee tables Rossellini, di cui riprendono – semplificandole - le forme e le linee leggermente stondate. A differenza dei Rossellini, che hanno il piano in Damantio® - materiale decorativo brevettato da Rubelli nel 2017, sinonimo di innovazione tecnologica applicata alla creatività - i Fellini vengono proposti con il piano in legno: Eucalipto pomelè naturale oppure noce naturale.

Inoltre le basi dei nuovi tavolini vedono unirsi in un unico corpo, un tubo a sezione rettangolare, il doppio “nastro” metallico, già elemento distintivo dei Rossellini.

Altre finiture: base struttura: 51.finitura bronzo, 54.finitura nickel nero lucido; top: 37.legno ecaulipto pomele naturale, 82.noce naturale.

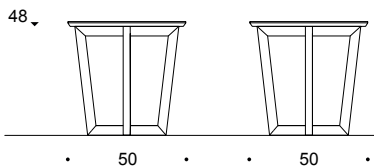

GRETA TRIO



Design M A R C O P I V A
Cod. A 1 6 0 0 2

Greta refers to the international film star Greta Garbo and her strong expressiveness. The Greta tables, available in three heights, create geometry from the intersection of the legs which project onto the top, dividing it into three modules coated with a combination of lacquer finishes and Damantio®, the exclusive material patented by Rubelli. A strong graphic mark breaks up the top and plays on the textural contrast. The tapered top allows a transparent view of the thickness and the preciousness of Damantio®.

Other finishings: structure: 54.polished black nickel finish; top: 40.polished tortora colour lacquer, 90.bronze Damantio®.

Greta rimanda alla stella internazionale del cinema Greta Garbo e alla sua decisa espressività. Rigore geometrico, declinato in tre altezze. I tavolini Grete creano una geometria nella geometria, dall'intersezione delle gambe che si proiettano sul piano d'appoggio, dividendolo in tre moduli, rivestiti con una combinazione di laccati e Damantio®, esclusivo materiale brevettato da Rubelli. Un segno grafico forte interrompe il piano e gioca sul contrasto materico. Il piano svasato permette di percepire in trasparenza la tridimensionalità e la preziosità del Damantio®.

Altre finiture: struttura: 54.finitura nickel nero lucido; top: 40.laccato lucido color tortora, 90.Damantio® bronzo.

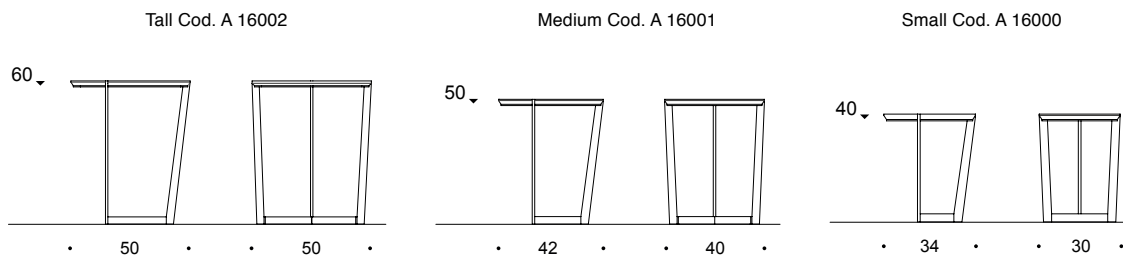



PABLO

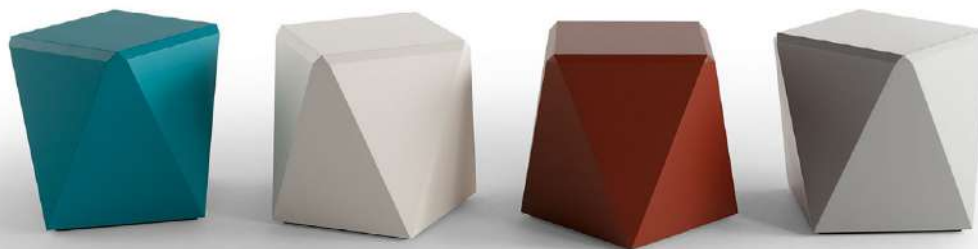

Design N A V A + A R O S I O
Cod. A 1 2 1 1 9

The geometry, with a double play on surface facets, marks out the sculptural and essential aspect of Pablo Piano in polyurethane, available in different matte lacquer finish colourways. Pablo Piano in polyurethane HD can be coordinated with other items in the Piano collection, creating a play on different heights and scenic effects.

Other finishings: 43.matt grey colour lacquer, 44.matt cream colour lacquer, 45.matt oxide red colour lacquer, 46.matt turquoise blue colour lacquer.

La geometria, con un doppio gioco di sfaccettature superficiali, scandisce l'aspetto scultoreo ed essenziale di Pablo Piano in poliuretano HD disponibile in differenti colorazioni laccate opache. Pablo Piano è accostabile agli altri elementi della "Piano Collection", creando un gioco di differenti altezze ed effetti scenografici.

Altre finiture: 43.laccato opaco color grigio, 44.laccato opaco color crema, 45.laccato opaco color rosso ossido, 46.laccato opaco color turchese blu.

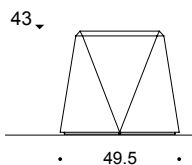

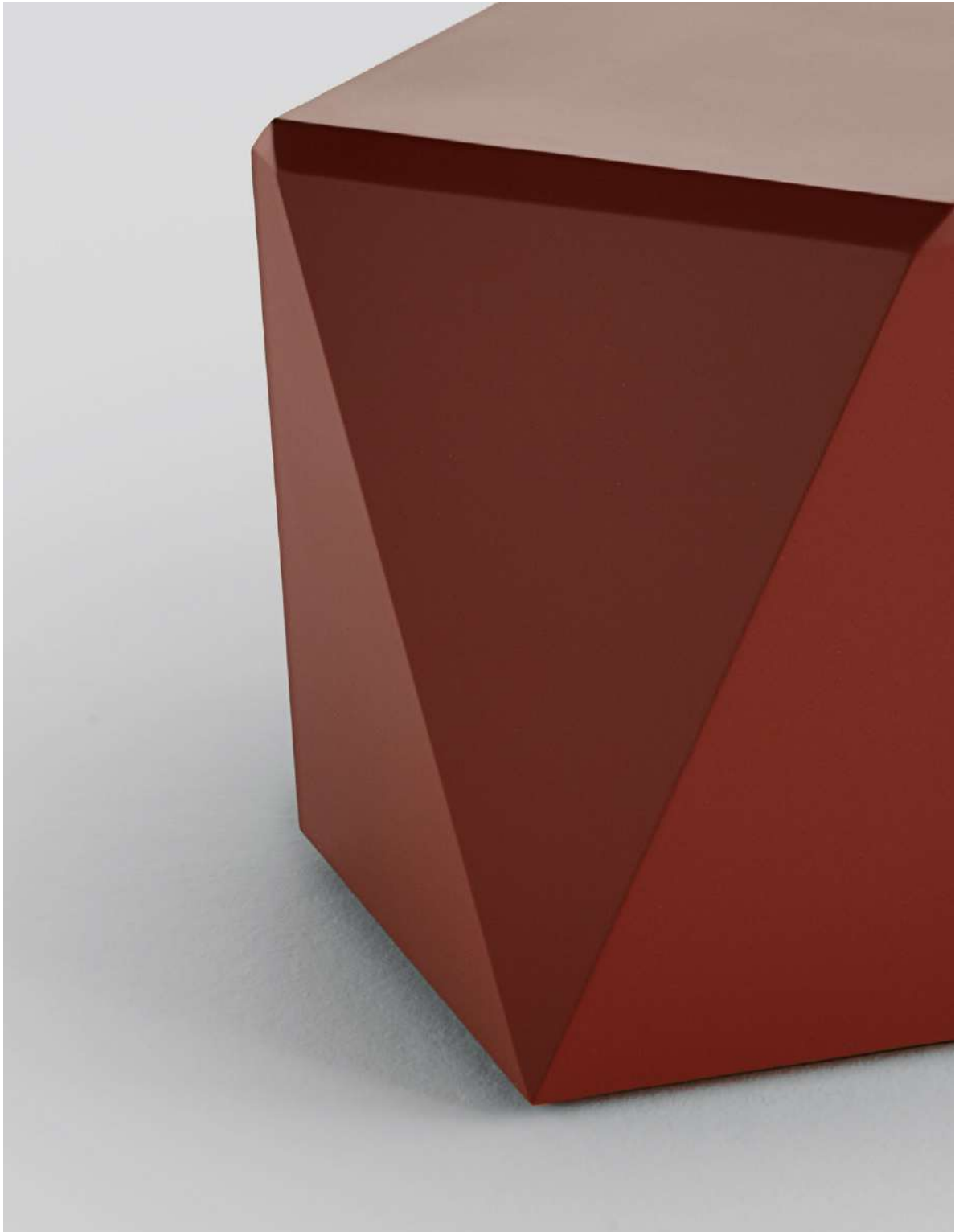

PEGGY



Design S T U D I O R U B E L L I
Cod. A 1 6 0 1 8

Intentionally and intrinsically glamorous, Peggy, designed by Rubelli Studio, is the most eccentric piece of furniture of the 2019 Rubelli Casa collection. As eccentric and unconventional as the American art collector Peggy Guggenheim, after whom the new Rubelli Casa item is named. Peggy is an exuberant and exclusive side table with a “lightweight” silhouette. It is entirely made in Damantio®, a decorative material created and patented by Rubelli in 2017, a byword for technological innovation applied to creativity. Damantio® is synonymous of a fabric (developed especially by Rubelli) incorporated in a special transparent resin and retaining its 3D appearance. Peggy captivates with its metallic glances and the trompe-l’oeil effect typical of Damantio®. Versatile thanks to its « ribbon » structure, this side table can be used in two positions, both vertically and horizontally, according to one’s specific needs.

Other finishings: 90.bronze Damantio®, 92.silver Damantio®.

Volutamente e intrinsecamente glamour, Peggy, disegnato da Studio Rubelli, è il pezzo più eccentrico della collezione Rubelli Casa 2019. Eccentrico e non convenzionale come la collezionista mecenate Peggy Guggenheim da cui prende il nome, Peggy è un tavolino esuberante e singolare, dalla silhouette “leggera”, interamente realizzato in Damantio®. Brevettato da Rubelli nel 2017, il Damantio® è un materiale decorativo, sinonimo di innovazione tecnologica applicata alla creatività: in una particolare resina viene “inglobato” un tessuto appositamente messo a punto per essere racchiuso nella lastra trasparente senza perdere la propria tridimensionalità. Peggy inevitabilmente cattura per i riflessi metallici e l’effetto trompe l’oeil proprio del Damantio®. Versatile grazie alla sua struttura “a nastro”, questo tavolino può essere utilizzato in due posizioni, orizzontale e verticale, in base alle esigenze del momento.

Altre finiture: 90.Damantio® bronzo, 92.Damantio® argento.

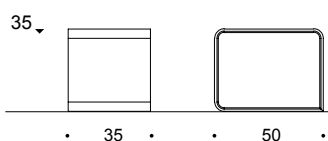



PIANO LARGE



Design NAVA + AROSIO
Cod. A 1 6 0 1 3 *Top* CALACATTA MARBLE

The geometry marks out the sculptural and essential aspect of this coffee table. The base in black nickel and the top in Calacatta marble encapsulate between two visual lines the control and appeal of facets and plays on light of the support structure, available in two different walnut versions. Piano Coffee Table Large can be coordinated with other items in the Piano collection, creating a play on different heights and scenic effects.

Other finishings: base: 82.natural walnut, 101.chocolate walnut; metal base: 100.matt black nichel finish; optional top: 73.Calacatta Vagli marble.

La geometria scandisce l'aspetto scultoreo ed essenziale di questo coffee table. Il basamento in nickel nero e il top in marmo Calacatta racchiudono tra due linee visive il rigore e la bellezza di sfaccettature e giochi di luce della struttura portante disponibile in due differenti varianti noce. Il Piano Coffee Table Large è accostabile agli altri elementi della "Piano Collection", creando un gioco di differenti altezze ed effetti scenografici.

Altre finiture: base: 82.noce naturale, 101.noce cioccolato; base metallo: 100.finitura nichel nero opaco; top opzionale: 73.marmo Calacatta Vagli.

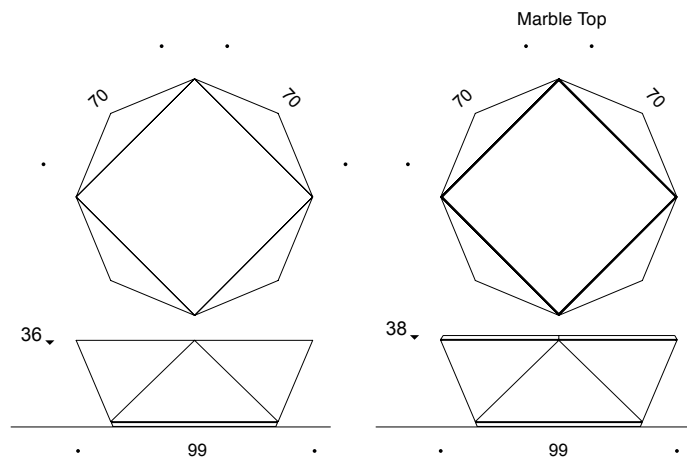



PIANO SMALL



Design N A V A + A R O S I O
Cod. A 1 6 0 1 2

The geometry marks out the sculptural and essential aspect of this coffee table. The base in black nickel and the top in Calacatta marble encapsulate between two visual lines the control and appeal of facets and plays on light of the support structure, available in two different walnut versions. Piano Coffee Table Large can be coordinated with other items in the Piano collection, creating a play on different heights and scenic effects.

Other finishings: base: 82.natural walnut, 101.chocolate walnut; metal base: 100.matt black nickel finish; optional top: 73.Calacatta Vagli marble.

La geometria scandisce l'aspetto scultoreo ed essenziale di questo coffee table. Il basamento in nickel nero e il top in marmo Calacatta racchiudono tra due linee visive il rigore e la bellezza di sfaccettature e giochi di luce della struttura portante disponibile in due differenti varianti noce. Il Piano Coffee Table Large è accostabile agli altri elementi della "Piano Collection", creando un gioco di differenti altezze ed effetti scenografici.

Altre finiture: base: 82.noce naturale, 101.noce cioccolato; base metallo: 100.finitura nickel nero opaco; top opzionale: 73.marmo Calacatta Vagli.

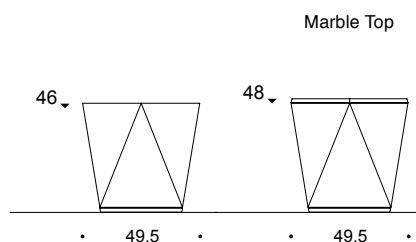



ROSSELLINI



Design M A R C O P I V A

Cod. A 1 6 0 0 4 O V A L *Cod.* A 1 6 0 0 5 S Q U A R E

Rossellini is a tribute to the famous couple Roberto and Isabella Rossellini. The tradition of the most sophisticated artisan work creates the coming together of the most exclusive materials from Rubelli Casa - metals and Damantio®, the exclusive material patented by Rubelli. The trio of coffee tables once again covers the same graphic line available in three different heights and soft shapes featuring slightly rounded forms.

Other finishings: structure: 51.bronze finish, 54.polished black nickel finish; top: 90.bronze Damantio®, 92.silver Damantio®.

Rossellini è un tributo alla famosa coppia Roberto e Isabella Rossellini. La tradizione della più raffinata lavorazione artigiana incontra i materiali più pregiati di Rubelli Casa: i metalli e il Damantio®, esclusivo materiale brevettato da Rubelli. I tre coffee tables ripercorrono lo stesso segno grafico proposto in diverse altezze e in morbide geometrie caratterizzate da forme leggermente stondate.

Altre finiture: struttura: 51.finitura bronzo, 54.finitura nickel nero lucido; top: 90.Damantio® bronzo, 92.Damantio® argento.

Tall Cod. A 16003

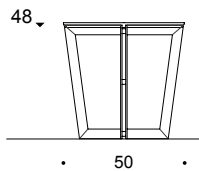

Oval Cod. A 16004

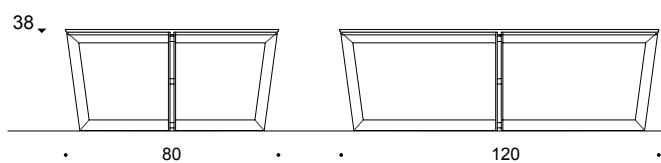

Square Cod. A 16005

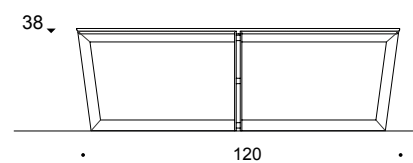



Design M A R C O P I V A
Cod. A 1 6 0 0 3 T A L L *Top* D A M A N T I O ® B R O N Z E

TELÈR



Design L U C A S C A C C H E T T I

Cod. A 1 2 0 5 9 S M A L L - A 1 2 0 6 0 T A L L

Cod. A 1 2 0 6 1 S Q U A R E - A 1 2 0 6 2 R E C T A N G U L A R

A set of small tables available in four different versions. The frame is in wenge stained ash while the top can either be in Fior di Pesco Carnico marble or in exclusive material Damantio® in colours bronze and silver. The Square and Rectangular models have lower surface in smoked tempered glass.

Set di tavolini declinati in quattro varianti. I Telèr Tables hanno la struttura in frassino tinto wengè, mentre il piano può essere in marmo Fior di Pesco Carnico o nell'esclusivo materiale Damantio® nei colori bronzo e argento. Il modello Square e il Rectangular hanno un piano inferiore in vetro temprato fumé.

Other finishings: structure: 21.wenge stain ashwood; base: 61.grey glass; top: 61.grey glass, 71.fior di pesco carnico marble, 90.bronze Damantio®, 92.silver Damantio®.

Altre finiture: struttura: 21.frassino tinto wengè; base: 61.vetro fumè; top: 61.vetro fumè, 71.marmo fior di pesco carnico, 90.Damantio® bronzo, 92.Damantio® argento.

Small Cod. A 12059

Tall Cod. A 12060

Square Cod. A 12061

Rectangular Cod. A 12062

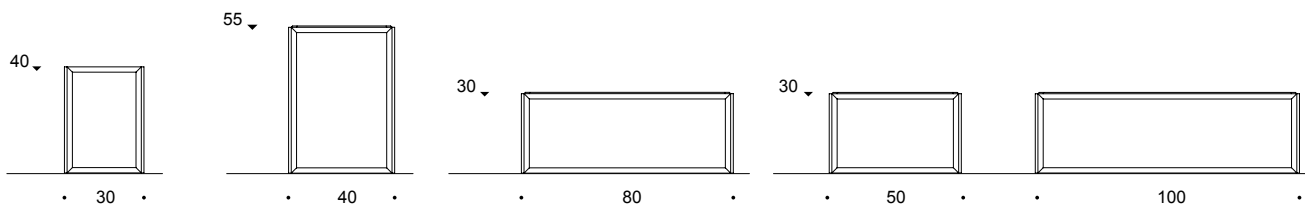



FÒRCOLA BAR CABINET



Design L U C A S C A C C H E T T I
Cod. A 1 2 0 9 2

Bar cabinet designed by Luca Scacchetti with base in black metal and frame in black lacquer finished wood.

The movement of the base and two handles are inspired by the forcole rowlocks of gondolas, streamlined Venetian oarlocks, combination of function and elegance.

The interior, embellished by mirrors, has two glass shelves. The doors are available in polished tortora, bronze color liquid metal lacquer or natural ammara ebony.

Other finishing: frame/base/handle: 00.black lacquer; doors: 34.natural ammara ebony, 40.polished tortora colour lacquer, 41.liquid metal in bronze colour lacquer.

Mobile bar creato da Luca Scacchetti con base in metallo nera e struttura in legno laccato nero. Il movimento della base e delle due maniglie è ispirato alle forcole delle gondole: gli slanciati scalmi veneziani sintesi di funzionalità ed eleganza. L'interno, arricchito da specchi, è dotato di due ripiani in vetro. Le ante sono disponibili in laccato color tortora, in laccato metallo liquido color bronzo o in ebano ammara naturale.

Altre finiture: struttura/maniglie: 00.laccato nero; ante: 34.ebano ammara naturale, 40.laccato lucido color tortora, 41.laccato metallo liquido color bronzo.

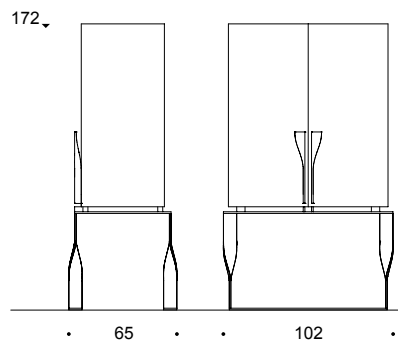



FRAME BOOKCASE



Design MATTEO NUNZIATI

Cod. A 1 6 0 2 5 *Fabrics selected* DIVA SHANTUNG / VELOURS SOLEIL

Frame is a bookcase inspired by the designs of Venice architect Carlo Scarpa, in whose works all the details are carefully researched and masterfully produced. A metallic frame in gloss black nickel runs around the outline of each single component of this furniture item, making it highly sophisticated and exclusive in its contemporary style. The shelves are in wood (Chocolate Walnut or Natural Walnut), while the external side panels are covered in fabric. LED lights are included as options to enhance the 3D nature of the back and the objects on the shelves and to make this bookcase an even more magical and alluring furniture item.

Other finishing: 82.natural walnut, 101.chocolate walnut, metal elements: 54.polished black nickel finish, 3D textile front panel, flat textile lateral and back panel.

Frame è una libreria ispirata ai progetti dell'architetto veneziano Carlo Scarpa, nelle cui opere tutti i dettagli sono accuratamente studiati e magistralmente realizzati. Una cornice metallica in nickel nero lucido corre intorno al perimetro di ogni singolo componente di questo elemento di arredo, rendendolo fortemente ricercato ed esclusivo nella sua contemporaneità. Gli scaffali sono realizzati in legno (noce cioccolato o noce naturale), i fianchi esterni sono rivestiti in tessuto. Per esaltare sia la tridimensionalità dello schienale che gli oggetti appoggiati sugli scaffali sono state previste delle luci opzionali a tecnologia Led, così da fare di questa libreria un complemento di arredo ancor più magico e seducente.

Altre finiture: 82.noce naturale, 101.noce cioccolato, elementi metallo: 54.nichel nero lucido, schienale interno con pannello in tessuto 3D, fianchi esterni / schienale esterno con pannello in tessuto liscio.

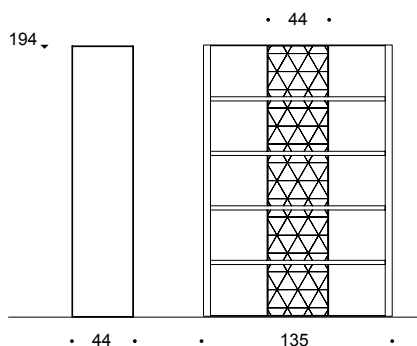



PIQUÉ LOW



Design MATTEO NUNZIATI

Cod. A 1 6 0 2 3 *Fabrics selected* DIVA SHANTUNG / VELOURS SOLEIL

Piqué is a range of storage units. The reference is a link to the Venetian architect Carlo Scarpa, in whose works all the details are perfectly studied and masterfully produced. The doors can be in wood (Chocolate Walnut and Natural Walnut) or upholstered in fabric (which can be customised to order with an exclusive 3D diamond decoration). They are embellished with a metal frame with polished black nickel finish.

Other finishing: 82.natural walnut, 101.chocolate walnut, metal elements & legs 54. polished black nickel finish, optional decorative element 3D textile panel front doors, flat textile panel lateral panel / front doors.

Piqué è un sistema di mobili contenitori. Il riferimento è legato all'architetto veneziano Carlo Scarpa, nelle cui opere tutti i dettagli sono perfettamente studiati e magistralmente realizzati. Le ante possono essere realizzate in legno (Chocolate walnut e Natural walnut) oppure rivestite in tessuto (che su richiesta può essere personalizzato con un'inedita decorazione tridimensionale a rombi). Le impreziosisce una cornice metallica con finitura nickel nero lucido.

Altre finiture: 82.noce naturale, 101.noce cioccolato, elementi metallo e gambe: 54.nichel nero lucido, elementi decorativi opzionali ante con pannello in tessuto 3D, fianchi esterni / ante con pannello in tessuto liscio.

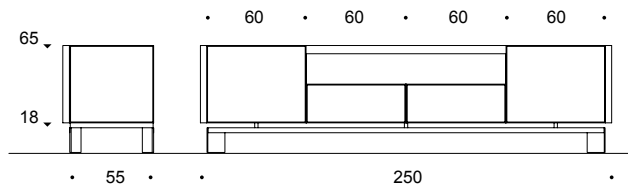



PIQUÉ TALL



Design MATTEO NUNZIATI

Cod. A 1 6 0 2 4 *Fabrics selected* DIVA SHANTUNG / VELOURS SOLEIL

Like the low cabinet the shapes are understated yet there is richness coming from the elaborately produced proportions, researched in depth, and the skilfully produced details in metal, fabric and wood. The variety of materials and finishes that live side by side, enhancing each other, allow designers to use this piece to furnish different areas of the home.

Other finishings: 82.natural walnut, 101.chocolate walnut, metal elements & legs 54.polished black nickel finish, optional decorative element 3D textile panel front doors, flat textile panel lateral panel / front doors.

Come per il cabinet low le forme sono essenziali, ma la ricchezza viene trasmessa dalla elaborata realizzazione delle proporzioni approfonditamente studiate e dei dettagli di metallo, tessuto e legno, magistralmente realizzati. La varietà di materiali e finiture che convivono tra di loro esaltandosi reciprocamente permettono al progettista di utilizzare questo pezzo per arredare differenti scenari domestici.

Altre finiture: 82.noce naturale, 101.noce cioccolato, elementi metallo e gambe: 54.nichel nero lucido, elementi decorativi opzionali ante con pannello in tessuto 3D, fianchi esterni / ante con pannello in tessuto liscio.

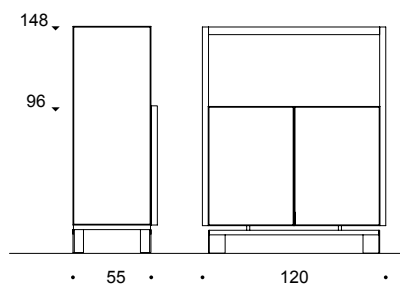



Design MATTEO NUNZIATI
Cod. A 16024 *Fabric* DIVA SHANTUNG CACHI ORO

RIO NOVO DESK



Design L U C A S C A C C H E T T I
Cod. A 1 2 0 3 3

Rio Novo is a desk designed by Luca Scacchetti, with highly elegant lines and proportions, to the extent of becoming an icon in the collection. The frame and lower surface are in wood Moka stain ashwood or natural ashwood, while the top is covered in leather and is fitted with two drawers with front leather panel. The feet and the handles insert are in metal with satin brass finish.

Other finishings: structure: 38.moka stain ashwood, 84.natural ashwood; metal elements: 56.satin brass finish.

Rio Novo è una scrivania progettata da Luca Scacchetti, elegantissima nelle sue forme e proporzioni, al punto da diventare un'icona della collezione. L'intelaiatura e il piano inferiore sono in frassino tinto moka o frassino naturale, mentre il piano superiore è rivestito in pelle ed è dotato di due cassetti con pannello frontale anch'esso in pelle. I piedini e l'inserto delle maniglie sono in metallo con finitura ottone satinato.

Altre finiture: struttura: 38.frassino tinto moka, 84.frassino naturale; elementi metallo: 56.finitura ottone satinato.

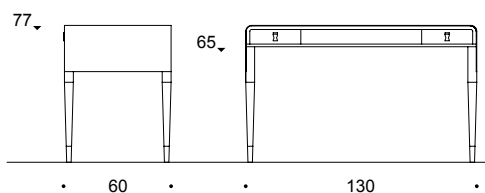



RÌO TERÁ



Design L U C A S C A C C H E T T I
Cod. A 1 2 0 7 4

Minimalist console with four legs, Rìo Terá comes in Moka stain ashwood. The slim, tapered legs make it lightweight and easy to fit in various living spaces. The top is covered in leather while the metal feet are available with satin brass finishes.

*Other finishings: structure: 38.moka stain ashwood;
metal elements: 56.satin brass finish.*

Console dalla linea essenziale a quattro gambe, Rìo Terá è realizzata in frassino tinto moka. Le esili gambe rastremate la rendono leggera e facilmente inseribile in diversi contesti abitativi. Il piano superiore è rivestito in pelle, mentre i piedini in metallo sono disponibili con finitura ottone satinato.

*Altre finiture: struttura: 38.frassino tinto moka;
elementi metallo: 56.finitura ottone satinato.*

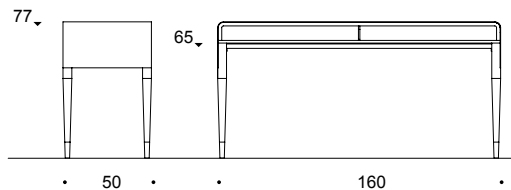



SCHOLÈTA



Design L U C A S C A C C H E T T I
Cod. A 1 2 0 7 8

Classic and timeless, the profile of Scholèta Console references a console archetype – rectangular, lightweight and versatile. With an Art Deco inspiration, the design by Luca Scacchetti includes a frame in black lacquer finish wood with decorative features, the feet and a sort of capital, in satin brass finish.

Other finishings: structure: 00.black lacquer; metal elements: 56.satin brass finish.

Classica e senza tempo, il profilo della Scholèta si rifà all'archetipo della console: rettangolare, leggera e versatile. Di ispirazione Art Déco, il progetto di Luca Scacchetti prevede una struttura in legno laccato nero con elementi decorativi - una sorta di capitello ed i piedini - in finitura ottone satinato.

Altre finiture: struttura: 00.laccato nero; elementi metallo: 56.finitura ottone satinato.

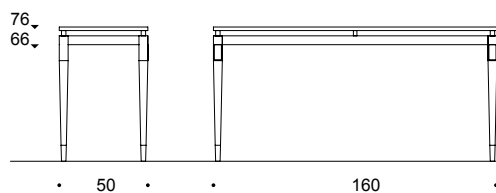



SCHOLÈTA LUXURY



Design L U C A S C A C C H E T T I
Cod. A 1 2 0 8 4

The top in Damantio® – exclusive material patented by Rubelli – in the bronze colour, characterises the Scholèta Console and makes it unique in its Luxury version. Like the standard version the frame is in black lacquer finished wood and the decorative features in satin brass finish.

Other finishings: structure: 00.black lacquer; metal elements: 56.satin brass finish; top: 90.bronze Damantio®.

Il piano in Damantio® - l'esclusivo materiale brevettato da Rubelli - nel colore bronzo caratterizza e rende unica Scholèta Console nella sua versione Luxury. Così come nella versione standard la struttura è in legno laccato nero e gli elementi decorativi in finitura ottone satinato.

Altre finiture: struttura: 00.laccato nero; elementi metallo: 56.finitura ottone satinato; top: 90.Damantio® bronzo.

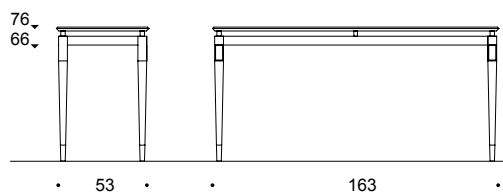



BOULE LAMP



Design M A T T E O N U N Z I A T I

Boule is a collection of contemporary lights in blown glass. The model is available in floor, table and suspension versions. The round yet elongated diffuser comes in two different finishes – plain grey glass or hand-engraved glass, so as to reference the typical decoration and texture of a Rubelli fabric. The support is understated in order to enhance the shapes and finishes of the diffuser. Boule is a timeless lamp, a furnishing accessory for elegant, exclusive spaces.

Other finishings: glass 63.satin hand- engraved grey glass, 64.satin smooth grey glass; metal elements 51.bronze finish.

Boule è una collezione di lampade contemporanee in vetro soffiato. Il modello viene proposto in versione da terra, da tavolo e sospensione. Il diffusore, di forma rotonda ma allungata, è presentato in due differenti finiture: vetro liscio grigio o vetro inciso manualmente, così da richiamare la texture e la decorazione tipiche di un tessuto Rubelli. Il supporto è essenziale per esaltare forma e finiture del diffusore. Boule è una lampada senza tempo: un complemento d'arredo per ambienti eleganti ed esclusivi.

Altre finiture: vetri 63.vetro grigio satinato inciso a mano, 64.vetro liscio grigio satinato; elementi in metallo 51.finitura bronzo.

Cod. A 16200

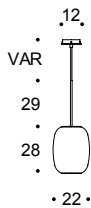

Cod. A 16201

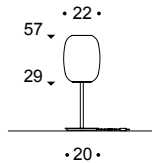

Cod. A 16202

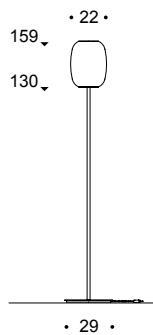

CUSTOM

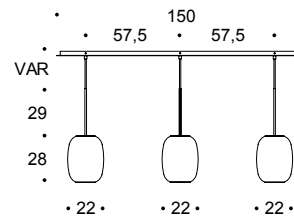

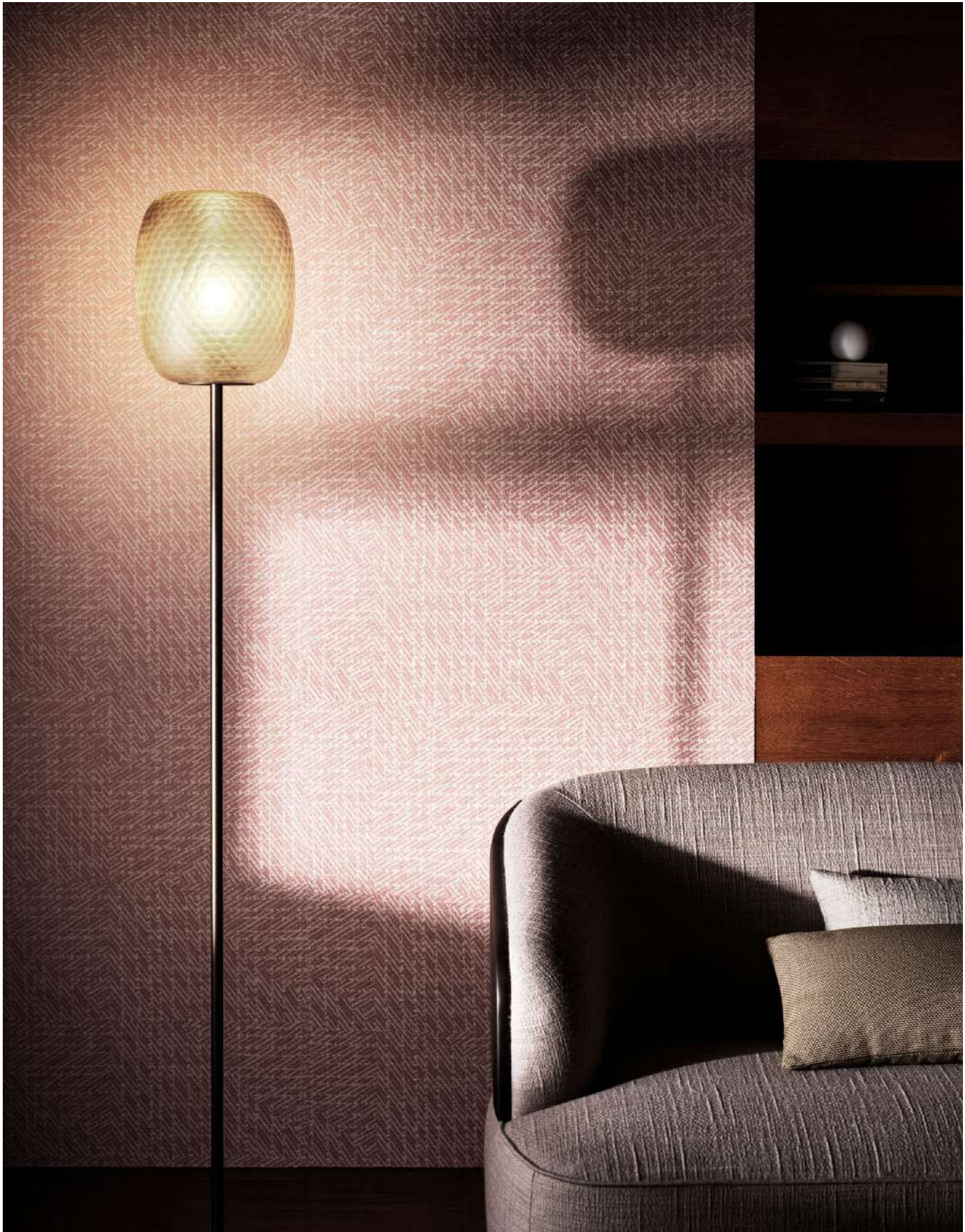

GILLO LARGE



Design S T U D I O R U B E L L I
Cod. A 1 4 0 0 6

Gillo, a mirror of the times. A homage to the art critic Gillo Dorfles. Sophisticated in its elongated octagonal shape, Gillo Large Mirror can be used both vertically and horizontally. The distinctive touch comes from the metal frame with an interior trim in Damantio®, the exclusive material patented by Rubelli. The mirror does the rest, virtually doubling the Damantio® itself and amplifying its distinctive 3D effect.

Option combinations: 54.polished black nickel finish - 90.bronze Damantio®; 54.polished black nickel finish - 92.silver Damantio®.

Gillo: specchio dei tempi. Omaggio al critico d'arte Gillo Dorfles. Gillo Large Mirror, ricercato nella sua forma ottagonale allungata, è utilizzabile sia in verticale che in orizzontale. Il tocco distintivo è dato dalla cornice metallica al cui interno è applicato un profilo di Damantio®, esclusivo materiale brevettato da Rubelli. Lo specchio fa il resto, raddoppiando virtualmente il Damantio® stesso e amplificandone l'effetto tridimensionale che lo contraddistingue.

Combinazioni: 54.finitura nickel nero lucido - 90.Damantio® bronzo; 54.finitura nickel nero lucido - 92.Damantio® argento.

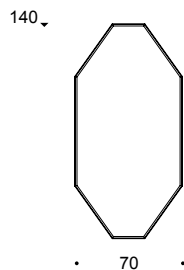



GILLO SQUARE



Design S T U D I O R U B E L L I
Cod. A 1 4 0 0 7

Gillo, a mirror of the times. A homage to the art critic Gillo Dorfles. Understated in its regular shape, Gillo Square Mirror can be turned through 45°: the length of the side corresponds to that of the oblique side of the octagonal model. This correlation enables multiple, elegant wall “combinations”. The distinctive touch comes from the metal frame with an interior trim in Damantio, the exclusive material patented by Rubelli. The mirror does the rest, virtually doubling the Damantio itself and amplifying its distinctive 3D effect.

Option combinations: 54.polished black nickel finish - 90.bronze Damantio®; 54.polished black nickel finish - 92.silver Damantio®.

Gillo: specchio dei tempi. Omaggio al critico d'arte Gillo Dorfles. Essenziale nella sua regolarità, Gillo Square Mirror può essere ruotato a 45°: la lunghezza del lato corrisponde a quella del lato obliquo del modello ottagonale. Questa correlazione rende possibili a parete molteplici ed eleganti “combinazioni”. Il tocco distintivo è dato dalla cornice metallica al cui interno è applicato un profilo di Damantio, esclusivo materiale brevettato da Rubelli. Lo specchio fa il resto, raddoppiando virtualmente il Damantio stesso e amplificandone l'effetto tridimensionale che lo contraddistingue.

Combinazioni: 54.finitura nickel nero lucido - 90.Damantio® bronzo; 54.finitura nickel nero lucido - 92.Damantio® argento.

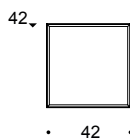



STAGE



Design M A T T E O N U N Z I A T I
Cod. A 1 2 1 4 1

Stage is a modular screen whose idea takes its inspiration from stage sets. A self-supporting hardwood frame allows fabrics to be hung, creating a sort of theatre backdrop. The different heights and modularity make Stage a flexible product, suited to every space. Perfect for partitioning rooms or simply placed against a wall, it becomes the ideal background for enhancing the appeal of the furniture in your home or in hotels etc. The possibility of “dressing” it with fabrics in the Rubelli collection means the screen can be interpreted in very many versions.

Other finishings: 38.moka stain ashwood.

Stage è un paravento modulare. L'idea è ispirata alle scenografie teatrali. Una struttura in legno massello autoportante permette di sospendere i tessuti creando una sorta di quinta teatrale. Le diverse altezze e la modularità permettono a Stage di essere un prodotto flessibile ed adatto ad ogni spazio. Ideale per dividere gli ambienti, oppure semplicemente accostato al muro, diviene una perfetta scenografia per esaltare la bellezza dei mobili della propria casa o degli spazi ricettivi. La possibilità di essere vestito con i tessuti della collezione Rubelli rende il paravento interpretabile in numerosissime varianti.

Altre finiture: 38.frassino tinto moka.

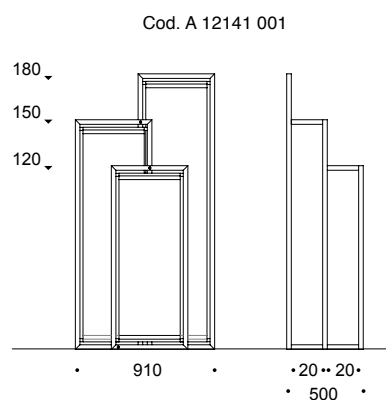
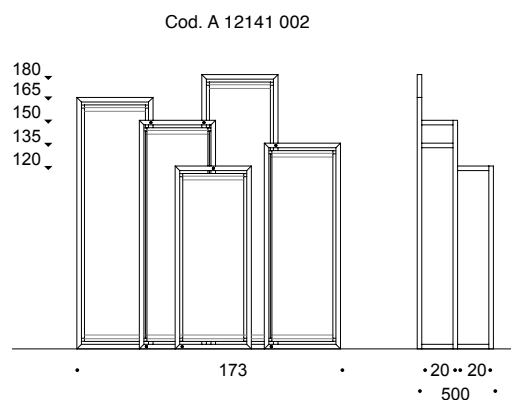



WALL ART

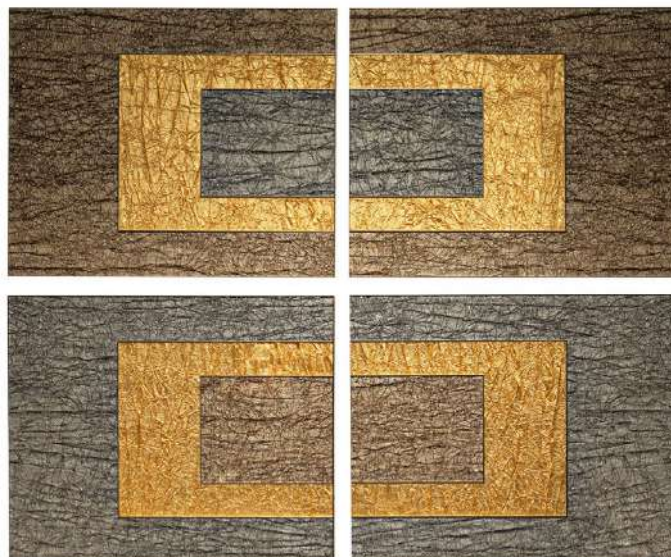

Design S T U D I O R U B E L L I

Wall Art is a decorative panel made in Damantio®, the material created and patented by Rubelli in 2017. Produced in Italy, Damantio® has a fabric developed specifically by Rubelli embedded in a special resin. Available in metallic gold, silver and bronze versions, its special feature is the retaining of its three-dimensionality. Wall Art enhances the beauty of this material with intrinsic textile links and allows endless combinations to be created, starting from the base panel which measures 240 cm x 120 cm with a thickness of 1 cm.

Option combination: 90.bronze Damantio®, 91.gold Damantio®, 92.silver Damantio®.

Wall Art è un pannello decorativo realizzato in Damantio®, materiale creato e brevettato da Rubelli nel 2017. Prodotto in Italia, il Damantio® ingloba in una particolare resina trasparente un tessuto appositamente messo a punto da Rubelli. Disponibile nelle varianti metalliche oro, argento e bronzo, ha la particolarità di conservare la propria tridimensionalità. Wall Art esalta la bellezza di questo materiale intrinsecamente legato al tessile e permette di creare infinite combinazioni, partendo dal pannello base che misura 240 cm x 120 cm con spessore di cm 1.

Option combination: 90.Damantio® bronzo, 91.Damantio® oro, 92.Damantio® argento.





LINGOTTO



Design S T U D I O R U B E L L I
Cod. A 1 2 0 9 3

The golden age. The Lingotto (i.e. the ingot) is an iconic shape with a modern interpretation. Covered with Aurum - a Rubelli fabric in pure gold and silk - and embellished by gold plated metal inserts. The richness is such that it creates in itself a precious object.

L'età dell'oro. Il Lingotto, una forma iconica interpretata nel presente. Rivestito con Aurum - tessuto in oro zecchino e seta - ed impreziosito da inserti metallici placcati oro. La ricchezza è tale che crea di per sé un oggetto prezioso.

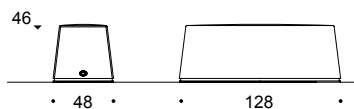



ABACUS



**ASOLA SOFA
ASOLA SOFA PLUS
ASOLA MODULAR SOFA**

Design Matteo Nunziati
Cod. A 12130 / A 12128 / A 12129
A 12131 - A 12136
pag. 54 / 57 / 58



CORTE NOVA III

Design Luca Scacchetti
Cod. A 12079
pag. 68



**DOMINO SOFA
DOMINO SOFA PLUS**

Design Nava + Arosio
Cod. A 12080 / A 12081
pag. 74 / 79



LOLLO

Design Marco Piva
Cod. A 12101
pag. 82



MARCELLO MODULAR SOFA

Design Marco Piva
Cod. A 12113 / A 12114 / A 12115
pag. 90



PALAZZO

Design Studio Rubelli
Cod. A 12083
pag. 96



**TRIENNALE 2
TRIENNALE 3**

Design Studio Rubelli
Cod. A 12105 / A 12106
pag. 120 / 125



**VELOUR SOFA
VELOR SOFA PLUS**

Design Matteo Nunziati
Cod. A 12124 / A 12125
pag. 130 / 134



DADAMAINO

Design Studio Rubelli
Cod. A 12103
pag. 72



SQUERARÒL

Design Luca Scacchetti
Cod. A 12047
pag. 114



BARBACÀN

Design Luca Scacchetti
Cod. A 12015
pag. 62



CANEVÌN

Design Luca Scacchetti
Cod. A 12011
pag. 64



CLINTÓN

Design Luca Scacchetti
Cod. A 12009
pag. 66



DOMINO ARM CHAIR

Design Nava + Arosio
Cod. A 12082
pag. 80



LOLLO TUB CHAIR

Design Marco Piva
Cod. A 12100
pag. 88



PILA-47

Design Nava + Arosio
Cod. A 66244
pag. 98



PILA LOUNGE

Design Nava + Arosio
Cod. A 66458
pag. 102



SILVANA

Design Marco Piva
Cod. A 12117
pag. 108



SILVANA LOUNGE

Design Marco Piva
Cod. A 12140
pag. 110



STEFANIA CLUB CHAIR

Design Marco Piva
Cod. A 12120
pag. 116



TELA

Design Matteo Nunziati
Cod. A 12121
pag. 118



TRIENNALE LOUNGE CHAIR

Design Studio Rubelli
Cod. A 12104
pag. 126



VELOUR ARM CHAIR

Design Matteo Nunziati
Cod. A 12123
pag. 136



VELOUR CHAISE LOUNGE

Design Matteo Nunziati
Cod. A 12126
pag. 135



ASOLA POUF

Design Matteo Nunziati
Cod. A 12137 / A 12138 / A 12139
pag. 60



PILA POUF

Design Nava + Arosio
Cod. A 66459
pag. 106



SOPHIA

Design Marco Piva
Cod. A 12099
pag. 112



**TWILL POUF D120
TWILL POUF D90**

Design Matteo Nunziati
Cod. A 12127 / A 12122
pag. 128

ABACUS



PIANO RECTANGULAR

Design Nava + Arosio
Cod. A 16020
pag. 148



PIANO ROUND

Design Nava + Arosio
Cod. A 16011 / A 16017
pag. 152



RODOLFO OVAL

Design Marco Piva
Cod. A 16007
pag. 154



RODOLFO ROUND

Design Marco Piva
Cod. A 16006
pag. 156



SCHOLA GRANDA CARD

Design Luca Scacchetti
Cod. A 12075
pag. 158



SCHOLA GRANDA FLOWER

Design Luca Scacchetti
Cod. A 12035
pag. 159



ANITA

Design Marco Piva
Cod. A 12095
pag. 138



ASCARI

Design Studio Rubelli
Cod. A 12097
pag. 140



B.B.

Design Marco Piva
Cod. A 12094
pag. 142



NUVOLARI

Design Studio Rubelli
Cod. A 12096
pag. 144



VIRNA

Design Marco Piva
Cod. A 12118
pag. 146



AGO

Design Matteo Nunziati
Cod. A 16019
pag. 162



ASOLA COFFEE TABLE

Design Matteo Nunziati
Cod. A 16022
pag. 164



BAÙTA LARGE

Design Luca Scacchetti
Cod. A 12064
pag. 166



BAÙTA TALL

Design Luca Scacchetti
Cod. A 12066
pag. 166



BAÙTA MEDIUM

Design Luca Scacchetti
Cod. A 12065
pag. 166



CALLE STELLA

Design Luca Scacchetti
Cod. A 12142
pag. 168



CONTRADA TRIO SMALL

Design Luca Scacchetti
Cod. A 16008
pag. 170



CONTRADA TRIO MEDIUM

Design Luca Scacchetti
Cod. A 16009
pag. 170



CONTRADA TRIO LARGE

Design Luca Scacchetti
Cod. A 16010
pag. 170



FELLINI OVAL

Design Marco Piva
Cod. A 16015
pag. 172



FELLINI SQUARE

Design Marco Piva
Cod. A 16016
pag. 174



FELLINI TALL

Design Marco Piva
Cod. A 16014
pag. 175



GRETA TRIO SMALL

Design Marco Piva
Cod. A 16000
pag. 176



GRETA TRIO MEDIUM

Design Marco Piva
Cod. A 16001
pag. 176



GRETA TRIO TALL

Design Marco Piva
Cod. A 16002
pag. 176



PABLO

Design Nava + Arosio
Cod. A 12119
pag. 178

ABACUS



PEGGY

Design Studio Rubelli
Cod. A 16018
pag. 180



PIANO LARGE

Design Nava + Arosio
Cod. A 16013
pag. 182



PIANO SMALL

Design Nava + Arosio
Cod. A 16012
pag. 184



ROSSELLINI OVAL

Design Marco Piva
Cod. A 16004
pag. 186



ROSSELLINI TALL

Design Marco Piva
Cod. A 16003
pag. 186



ROSSELLINI SQUARE

Design Marco Piva
Cod. A 16005
pag. 186



TELER RECTANGULAR

Design Luca Scacchetti
Cod. A 12062
pag. 188



TELÈR SMALL

Design Luca Scacchetti
Cod. A 12059
pag. 188



TELER SQUARE

Design Luca Scacchetti
Cod. A 12061
pag. 188



TELER TALL

Design Luca Scacchetti
Cod. A 12060
pag. 188



FÒRCOLA BAR CABINET

Design Luca Scacchetti
Cod. A 12092
pag. 190



FRAME BOOKCASE

Design Matteo Nunziati
Cod. A 16025
pag. 192



PIQUE LOW

Design Matteo Nunziati
Cod. A 16023
pag. 194



PIQUE TALL

Design Matteo Nunziati
Cod. A 16024
pag. 196



RIO NOVO

Design Luca Scacchetti
Cod. A 12033
pag. 198



RIO TERÁ

Design Luca Scacchetti
Cod. A 12074
pag. 200



SCHOLÈTA

Design Luca Scacchetti
Cod. A 12078
pag. 202



SCHOLÈTA LUXURY

Design Luca Scacchetti
Cod. A 12084
pag. 204



BOULE TABLE LAMP

Design Matteo Nunziati
Cod. A 16201
pag. 206



BOULE FLOOR LAMP

Design Matteo Nunziati
Cod. A 16202
pag. 206



BOULE PENDANT LAMP

Design Matteo Nunziati
Cod. A 16200
pag. 206



GILLO LARGE

Design Studio Rubelli
Cod. A 14006
pag. 208



GILLO SQUARE

Design Studio Rubelli
Cod. A 14007
pag. 210



STAGE

Design Studio Rubelli
Cod. A 12141
pag. 212



WALL ART

Design Studio Rubelli
pag. 214



LINGOTTO

Design Studio Rubelli
Cod. A 12093
pag. 216

FINISHINGS



00.
black lacquer
laccato nero

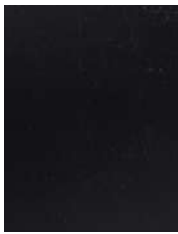

01.
stained in dark wenge
tinto wengè scuro



21.
wenge stain
ashwood
frassino tinto wengè



34.
natural ammara
ebony
ebano ammara
naturale



37.
eucalyptus pomele
natural
legno ecaulipto
pomele naturale



38.
moka stain ashwood
frassino tinto moka



82.
natural walnut
noce naturale



84.
natural ashwood
frassino naturale



101.
chocolate walnut
noce cioccolato



102.
brown leather
pelle marrone



103.
tortora leather
pelle tortora



90.
bronze Damantio®
Damantio® bronzo



92.
silver Damantio®
Damantio® argento



40.
polished tortora
colour lacquer
laccato lucido
color tortora



41.
liquid metal in bronze
colour lacquer
laccato metallo
liquido color bronzo

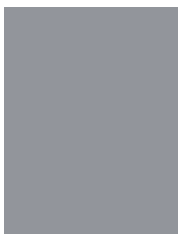

43.
matt grey colour
lacquer (ral 7004)
laccato opaco
grigio

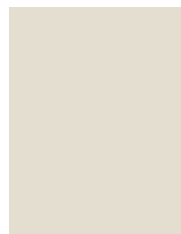

44.
matt cream colour
lacquer (ral 9001)
laccato opaco
color crema



45.
matt oxide red colour
lacquer (ral 3009)
laccato opaco
color rosso ossido

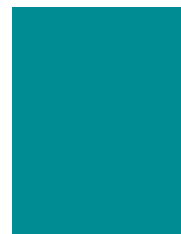

46.
matt turquoise blue
colour lacquer
(ral 5018)
laccato opaco
color turchese blu



71.
fior di pesco carnico
marble
marmo fior di pesco
carnico

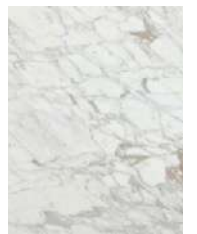

73.
Calacatta Vagli
marble
marmo Calacatta
Vagli



74.
Emperador dark
marble
marmo Emperador
dark

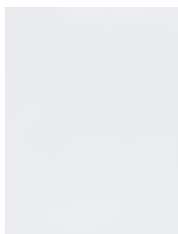

60.
extra clear glass
vetro extra chiaro



61.
grey glass
vetro fumè

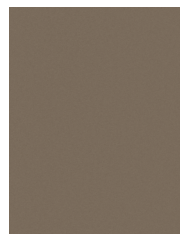

62.
bronze glass
vetro bronzato



63.
satin hand-engraved
grey glass
vetro grigio satinato
inciso a mano



64.
satin smooth grey
glass
vetro liscio grigio
satinato



51.
bronze finish
finitura bronzo

Descriptions and pictures of products included in this catalogue have an indicative value only and are not binding for products' use.

La descrizione e le immagini dei prodotti del presente catalogo sono puramente indicative e non possono essere considerate vincolati ai fini del loro utilizzo.



53.
satin steel finish
finitura acciaio
satinato

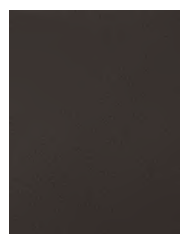

54.
polished black
nickel finish
finitura nickel
nero lucido



55.
satin nickel finish
finitura nickel
satinato



56.
satin brass finish
finitura ottone
satinato



100.
matt black nickel
finish
finitura nickel
nero opaco

Art direction Matteo Nunziati
Graphic project Lorenzo De Grandis
Photo Matteo Imbriani
Styling Cristina Nava

Thanks to:

Agustina Bottoni
Allina & Matteo Cor
Astep
Aurel K. Basedow
Bitossi
Bloc Studios
Cc-tapis
Colé Italia
Compasso Gallery, Milano
Illulian - Luxurious Custom Handmade Rugs
NasoNMoretti
Paola C.
Salvatori_official
Sambonet
Schreiber Collezioni Torino
Society Limonta
Tato

SHOWROOMS

VENEZIA

Ca' Pisani Rubelli
San Marco 3393
tel. +39 041 52 36 110

MILANO

Via Fatebenefratelli, 9
tel. +39 02 720 93 665

PARIS

11/13 Rue de l'Abbaye
tel. +33 1 56 81 20 20

LONDON

Chelsea Harbour Design Center East
tel. +44 207 349 15 90

DUBAI

PO Box 26604
Dubai, U.A.E.
tel. +971 4 443 5012

Tutti i componenti lignei all'interno dei prodotti
Rubelli Casa sono certificati secondo U.S. EPA TSCA
Title VI (CARB ATCM Phase II)

All products in this catalogue are 100% Made in Italy.
To browse all the Rubelli Group collections and for
technical info, please visit www.rubelli.com.

Any reproduction, representation or modification,
in full or partly, is expressly prohibited.

Tutti i prodotti in questo catalogo sono fatti
interamente in Italia.
Per conoscere tutte le collezioni del Gruppo Rubelli e
scaricare il materiale tecnico, si prega di visitare il sito
www.rubelli.com.

È espressamente vietata qualsiasi riproduzione, copia
o modifica, anche parziale, del presente catalogo.

©2020 Rubelli Casa - All rights reserved





RUBELLCASA.COM

